



Traffic Safety Corporation  
 2708 47th Ave.  
 Sacramento, CA 95822-3806  
 Toll Free: 888.446.9255  
 Tel: 916.394.9884  
 Fax: 916.394.2809  
 Email: sales@xwalk.com  
 Web: www.xwalk.com

TS-600

## Fully-Flush, Self-Cleaning, Bi-Directional Fixture In-Roadway Warning Lighting Systems

### General Description

The TS-600 fixture is designed for In-Roadway Warning Lighting Systems installed in snowplow areas. Their enhanced self-cleaning feature makes them ideal for installations with inclines. And the use of High-bright LED technology makes them the perfect choice for solar powered applications where power consumption must be minimized. The Bi-Directional design allows backlighting of pedestrians in the crosswalk, further improving the pedestrian safety. The TS-600 comes standard as a bi-directional fixture, but may be customized to a uni-directional fixture (TS-601).

The TS-600 is typically used in crosswalk applications, but is often used in school zone or rail-road crossing, lane control for bridges and tunnels, wrong way warning, and toll booth or toll way lead-on applications.

All In-Roadway Warning Lighting System components are available from TSC. A typical installation would include a set of fixtures, a control system, one or more activation devices such as a pedestrian push button station or pedestrian detection pad, and flashing LED crossing signs.

### Why Our TS-600 Is Better

#### Outstanding Durability

- Corrosion resistant anodized aluminum body stands up to traffic wear and weather.
- Fully flush profile avoids damage that may be caused by snowplows.
- High static load rating (44,000 lb.) reduces likelihood of damage from heavy vehicles.

#### Superior Visibility and Energy Efficiency

- Bi-directional design improves visibility of pedestrians in crosswalk.
- High-bright LEDs are 250 times brighter than the Caltrans minimum standard making them clearly visible in daytime and under the worst weather conditions.



*TS-600 Fully Flush  
 Bidirectional Fixture*

- High-bright LEDs consume only 2.5 watts per cartridge (5 watts per fixture) making them ideal for energy efficient solar power applications.

#### Low Maintenance

- Re-usable design reduces the cost, effort and time during resurfacing of the road.
- Self-cleaning lens design reduces build-up of dirt and need for frequent cleaning.
- Pre-focused optics eliminates the requirement of field adjustments.
- Long life LEDs (Average rated life of 10 years) reduces frequency of replacement.
- Factory sealed optical cartridge design reduces field maintenance issues.

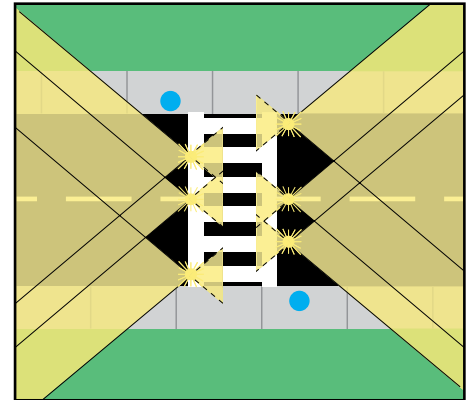

*Application: Two Way,  
 One Lane Each Way*

### Ordering Codes

Fixture	LED Color	Lamp	Options
TS-600 Bi-directional	_____ / _____	L: 12V LED Array	D: Dimming
TS-601 Uni-directional	_____	LP: 120V/240V LED 50/60hz	

- Notes:
1. LED Color: Y = Yellow, R = Red, X = Blank (Specify both lens).
  2. Standard fixture operating voltage is 12 VDC. Fixtures may also be operated from 24 VDC in certain applications.
  3. TSC supports legacy fixtures with Halogen or LED lamps (Special Order).
  4. Base Cans (BA-725-5-2), Base Can Extensions (BA-725-EX-XX), Spacers (BA-725-SP-XX) and Gaskets (BA-725-GSK) are available for the TS-600 Fixture.
  5. Power consumption is 2.5 watts per cartridge.
  6. Female Connector (CO-1051903021) is available for power source hook-up. Bi-directional fixture requires two female connectors, uni-directional fixture requires one female connector.
  7. Dimming option will only work with the TS1200 and TS1250 controllers.

Visit our web site: [www.xwalk.com](http://www.xwalk.com)



Traffic Safety Corporation  
 2708 47th Ave.  
 Sacramento, CA 95822-3806  
 Toll Free: 888.446.9255  
 Tel: 916.394.9884  
 Fax: 916.394.2809  
 Email: sales@xwalk.com  
 Web: www.xwalk.com

TS-600

## Fully-Flush, Self-Cleaning, Bi-Directional Fixture In-Roadway Warning Lighting Systems

### How to Specify the TS-600 Fully-Flush, Self-Cleaning, Bi-Directional Fixture

The fixture shall be model TS-600 as marketed by Traffic Safety Corporation or approved equal. In order to be considered equal, the alternate fixture shall satisfy the following requirements.

**Construction** - The fixture shall be bi-directional and of modular design comprised of a top casting and two (2) pre-focused optical cartridges made of high tensile strength aluminum alloy. The fixture shall be 0.00" above grade when mounted in the factory supplied mounting base. The diameter of the fixture shall not exceed 8" and all mounting hardware shall be stainless steel.

**Durability** - The fixture shall withstand a static load of 44,000 lb. without sustaining permanent deformation or cracking of materials. Leads, gaskets, etc. shall be rated to withstand 300 degrees F.

**LED/Light Cartridge** - Each lens shall be molded of high performance optical grade glass and formed in a removable factory sealed optical cartridge. Two cartridges required per fixture. Each cartridge consumes 2.5 watts per cartridge (5 watts per fixture) during the activation period of the fixture.

**Photometric Performance** - The fixture shall have both daytime and nighttime visibility exceeding that of a 50-watt halogen lamp, using a yellow light.

**Finish** - The fixture shall be anodized natural aluminum and be dark grey in color.

**Mounting Base** - Fixtures shall be installed in a mounting base (*TSC's #BA-725-5-2MR*) of high strength steel, hot dip galvanized after fabrication per ASTM-153 specifications, with a 7.25" diameter bolt circle, a 0.75" mud ring, and standard base depth of 5". The mud ring shall be detachable from the base. Mounting base without mud ring shall be made available upon request. The base shall be supplied with stainless steel bolts and a plywood cover to protect the mounting flange during installation. The height of the base shall be adjustable using spacers or extensions to facilitate roadway resurfacing.

**Warranty** - The fixture shall be warranted against defects in workmanship and materials for one year from date of shipment and is eligible for TSC's 5-Year Limited System Warranty.

### Replacement Parts

P/N	Name
TS-600LHC-YL	Cartridge Assembly: includes laminated lens (item #3), O-ring R3162 (item #4), lamp holder (item #5), LED (item #8A), LED Driver (item #8B), cylinder spring (item #9), MBX20 DIN 963 SS screw (item #1), O-ring R147 (item #10), end closure (item #11), cable gland (item #12), male fixture lead (item #13).
TS-600EC	End Closure Assembly: includes O-ring R147 (item #10), end closure (item #11), cable gland (item #12), male fixture lead (item #13).

#### Legacy Halogen Parts (not shown)

LA-Q50MR16FL	Lamp (120V)
Y=AL-852CFY	Color filter
AL-852-FS	Fixing spring

\* Component breakout is for legacy fixtures which are field replaceable. The current TS-600 Fixture uses the L4 LED array which is factory replaceable.

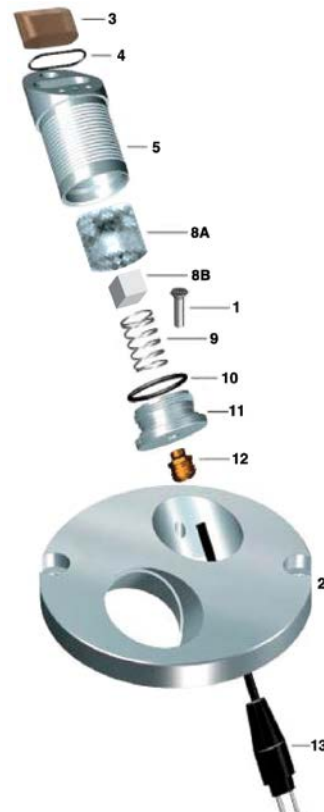

Visit our web site: [www.xwalk.com](http://www.xwalk.com)



**Traffic Safety Corporation**  
 2708 47th Ave.  
 Sacramento, CA 95822-3806  
 Toll Free: 888.446.9255  
 Tel: 916.394.9884  
 Fax: 916.394.2809  
 Email: sales@xwalk.com  
 Web: www.xwalk.com

**TS-600**

**Fully-Flush, Self-Cleaning, Bi-Directional Fixture  
 In-Roadway Warning Lighting Systems**

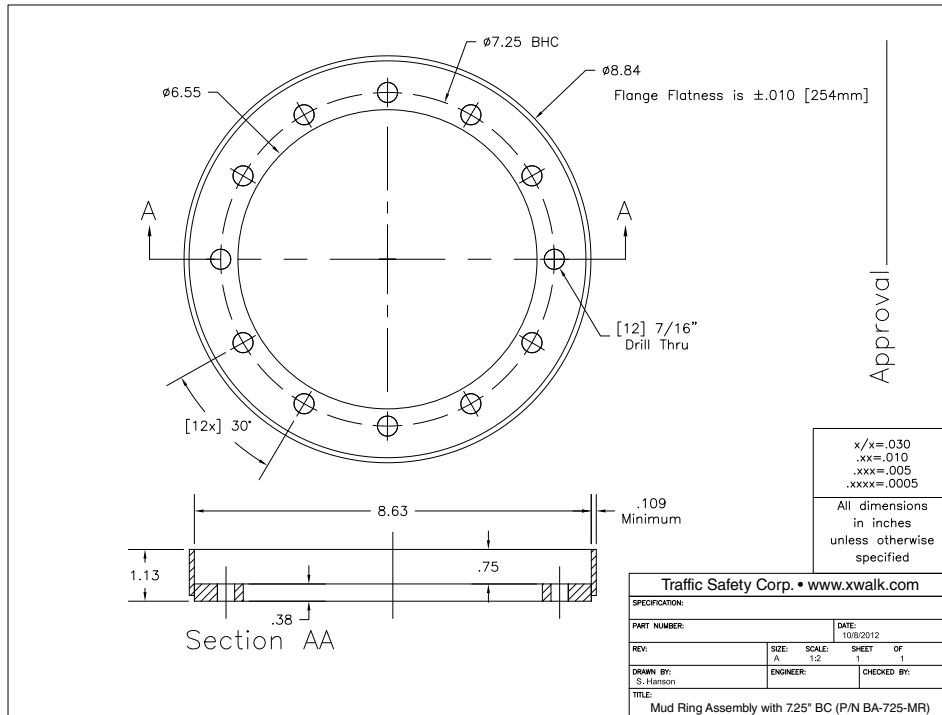
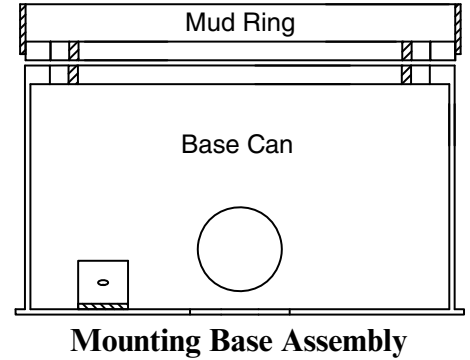
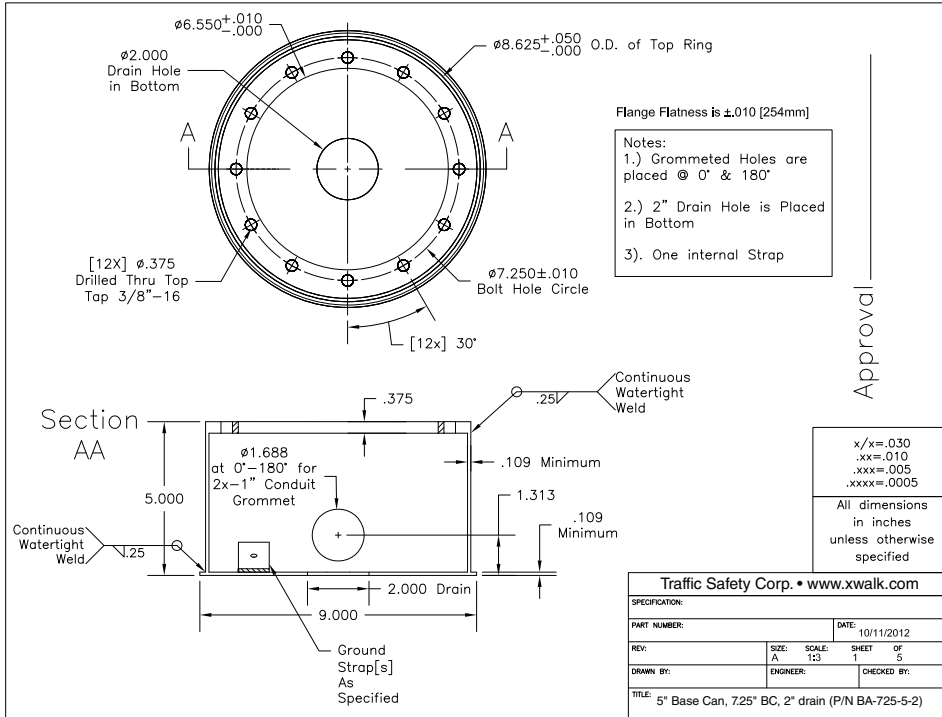

**Visit our web site: [www.xwalk.com](http://www.xwalk.com)**