TRAFFIC SAFETY CORPORATION

In-Roadway Warning Light System
AC Powered TS1200 Crosswalk System Controller
Installation and Owner's Manual



**TRAFFIC
SAFETY** CORP.
www.xwalk.com

TSC Technical Support Center
888-446-9255

Tel: 916.394.9884 Fax: 916.394.2809



JANUARY 21, 2025

TS1200-IM

Rev. E

Technical Support Center Reference Information

System Controller Part Number _____

Controller Serial Number _____

Fixture Model Number _____

Number of Fixtures _____

Date of Shipment _____

Retain this installation and user manual as a permanent record of your system purchase and as a reference in the event that warranty Service is required.

Register Your System

TSC has provided a convenient and efficient way to register your new system on-line at www.xwalk.com/registration. Registration is required within 1-Year of the date of shipment to qualify the system for TSC's 5-Year Limited System Warranty.

By registering your system with TSC, you will be recorded as the owner of the system. Your registration with TSC:

Will serve as confirmation of your system purchase and qualify your system for TSC's 5 Year Limited System Warranty.

Provide us with information required for quick servicing or your requests.

Help us notify you of enhancements or modifications to your system.

Contents

Introduction	1
Section 1 – General Information	2
A. Warranty Requirements	2
B. Installation Precautions and Recommendations	2
C. Technical Support Center Information:	2
Section 2 – In-Pavement Fixture Installation	3
A. Proper Placement of Fixtures	3
B. Drainage System Requirements	5
C. Drainage System Design	5
D. Base Can Installation – Core Drill and Saw Cut (Figure 1)	6
E. Base Can Installation – Trench and Fill – Option 1 (Figure 2)	7
F. Base Can Installation – Trench and Fill – Option 2 (Figure 3)	10
Section 3 – Electrical System Installation	12
A. Fixture Cabling	12
1) Fixtures	12
B. Fixture Connections	13
C. System Controller Description	14
D. System Controller Installation	16
E. Wiring and Operation of Activation Options	19
1. Push-Button	19
2. Photo-Sensor Bollards	20
3. TCB26-B Vehicle Sensor	26
F. System Controller Setup Instructions	28
Section 4 – Maintenance	28
A. Fixtures	28
B. Base Cans	28
C. Lenses	28
D. LED Lamp Replacement	29
Appendix A – TS1200 Troubleshooting Guidelines	29
Appendix B – TS1200 Component Replacement List	32
Appendix C – Fixture Cabling Test	32
Appendix D – Limited System and Product Warranties	33
Appendix E – Core Drill and Saw Cut Installation Pictures	34

Introduction

Traffic Safety Corporation's In-Roadway Warning Lighting System is one of the most durable and reliable lighting systems ever developed. To ensure the integrity of the system over its lifetime the system must be properly installed. Failure to install the system properly will negatively impact the performance of the system, shorten its life and may void the manufacturer's warranty.

The proper installation and operation of your system is our top priority. For that reason this installation manual has been designed to guide you through each of the major steps of the in-pavement and electrical installation of the system. We recommend that a copy of the manual be given to both the design engineer and the installer of your system, well in advance of the actual installation.

The major steps covered in this manual include:

A. In-pavement Installation

1. Proper Placement of Fixtures
2. Drainage System Requirements and Design
3. Base Can Installation

B. Electrical Installation

1. Fixture Cabling and Connection
2. Activation and Pre-warning Device Cabling
3. System Controller Connection

Please call if you have any questions or concerns about the installation requirements, system set-up or operation. Suggestions for improving our installation manual are welcomed. The TSC Technical Support Center can be reached, toll-free, at 1-888-446-9255.

Section 1 – General Information

A. Warranty Requirements

TSC offers a 5-Year Limited System Warranty on its In-Roadway Warning Lighting System, the industry's longest warranty. In order to qualify for the warranty the following requirements need to be met:

1. System must be installed properly. Failure to install the system properly may affect the integrity of the system and shorten its life.
2. Use only the TSC supplied components shipped with your system. This is a matched component system and the use of any other components may affect system performance or damage the system.
3. Do not replace High Bright LED Arrays in the field. The long-life High Bright LED arrays are replaceable only in the factory. Factory replacement includes overall fixture inspection, replacement of the LED array(s), replacement of the gaskets and/or O-Rings, validation of seal and LED burn-in.
4. The TSC system must be registered with TSC using the on-line system in order to activate TSC's 5-Year Limited System Warranty.

B. Installation Precautions and Recommendations

1. Verify that the drainage system is working properly by pouring water into the drain hole of each base can before pouring concrete, and checking that the underlying drainage is absorbing the water. This should be done after the core drilling or trenching, but before the fixture is installed and the concrete is poured. The water absorption test is done prior to pouring concrete so that, if the drainage system is not performing properly, it can be repaired without having to remove and then re-pour the concrete.
2. Verify that the base cans have been installed level with the road surface and are positioned so that when the fixtures are installed, they will point parallel to the direction of traffic flow.
3. Base cans are shipped with a protective plywood cover, TSC's Part# BA-PLCVR-3/4. The cover is used to protect the flange ring and keep debris out of the base can during installation, whenever the fixtures need to be removed for routine maintenance, during road resurfacing or during fixture shipment. After installation, the plywood covers should be marked, "DO NOT DISCARD", and stored in a safe location until needed.

C. Technical Support Center Information:

If You Have Any Questions or Concerns Call TSC Technical Support Center Before Proceeding: Open M-F, 7:30 AM to 4 PM PST @ 1-888-446-9255 Toll Free number.

Section 2 – In-Pavement Fixture Installation

A. Proper Placement of Fixtures

Refer to the design engineer's drawings for recommended placement of fixtures. Orient the base cans so that the fixtures will point parallel to the direction of on-coming traffic. Many possible fixture configurations are possible depending on the type of road that the crosswalk is being installed across. Typical layouts for the more common installations are shown below:

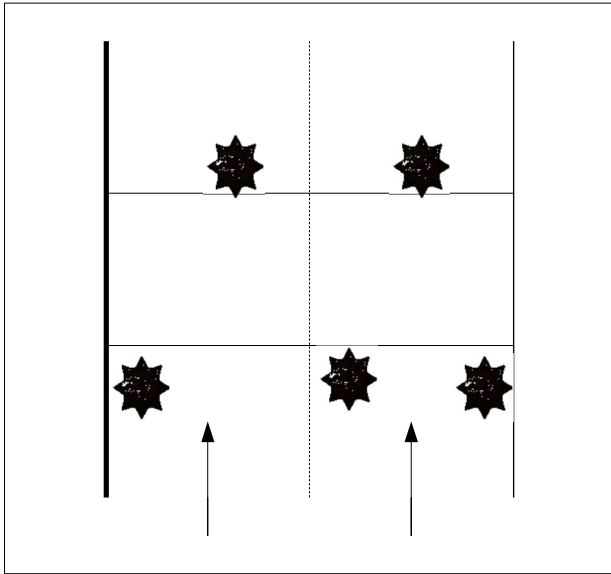

Two Lane, One Way

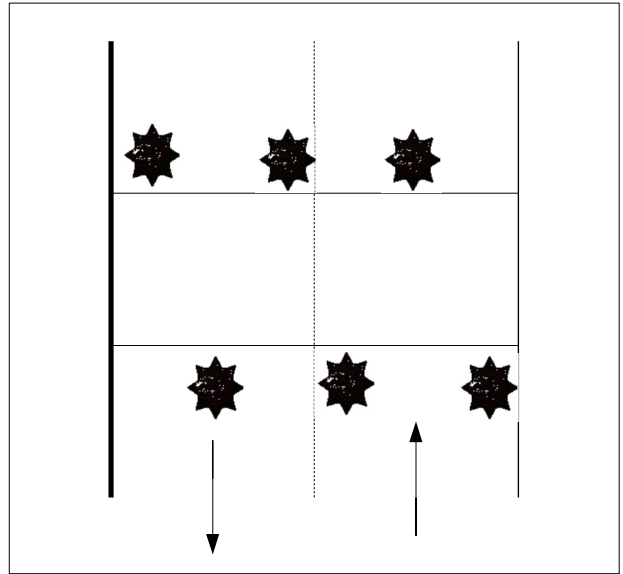

Two Lane, Two Way

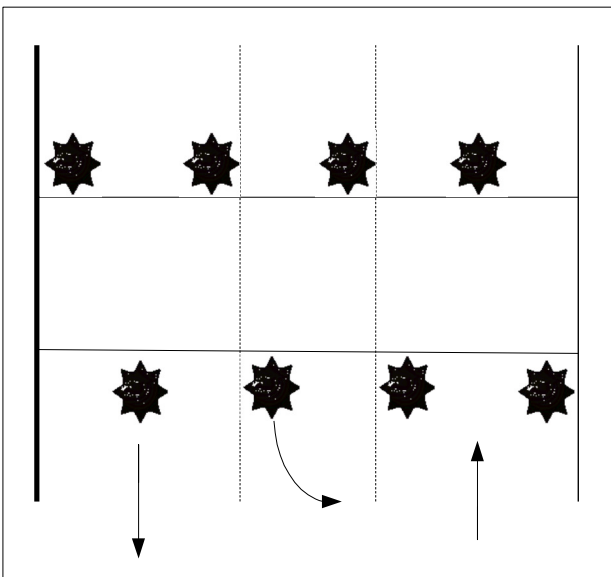

Two Lane with Turn Lane

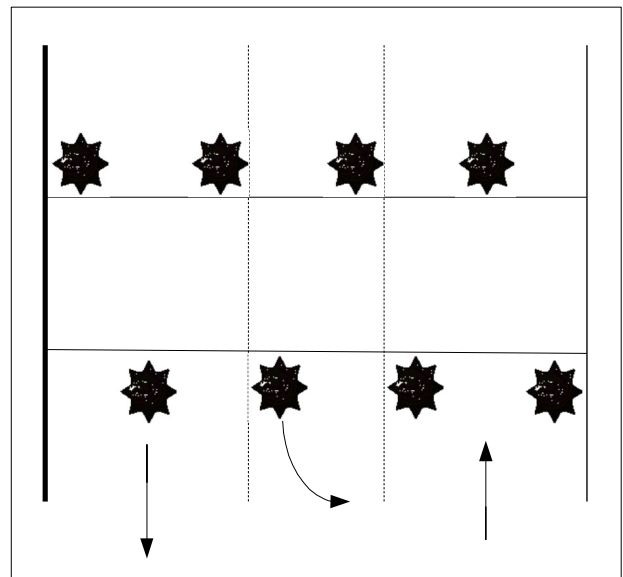

Four Lane, Two Way

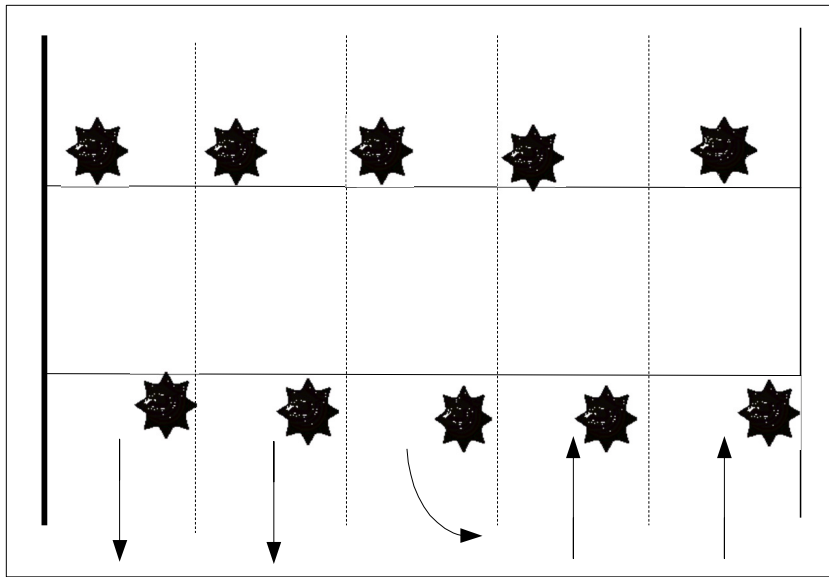

Four Lane, Two Way with Turn Lane



Typical Fixture Layout for Two Lane Road

B. Drainage System Requirements

The truism that water and electricity don't mix holds for In-Roadway Lighting Systems. Roadway pavement is subject to many sources of moisture, the most serious of which is ground water. The TSC In-roadway lighting system is designed to prevent water and water vapor from making contact with electrical conductors, contacts and connections. Fixtures used in the TSC system employ seals that prevent moisture from entering the light fixture. The connectors used are waterproof and provide connection between the fixture, and control system without fear of electrical shorting to ground. However, water within the base cans, left for long periods of time, may create problems. Standing water in the base can is especially undesirable in colder climates because of damage that can be done when water freezes and expands. To prevent problems caused by standing water in the base cans a proper drainage system must be designed and prior to the electrical installation of the fixtures and pouring of concrete. Failure to install a proper drainage system may result in damage to the system components.

C. Drainage System Design

A number of drainage system designs may be used to provide proper drainage for the TSC In-roadway warning light system. Two types of drainage systems are typically used in the installation of the system:

- Modified French Drain – This drain typically consists of a 1 1/2 inch diameter PVC pipe discharging into a drain rock section, which is installed directly under the drain hole of the base can. See Figures 1 and 2 that are located on pages 7 and 9 respectively.
- Piped Drain - This drain provides positive drainage from each base can through a pipe system that carries any water that gets into the system off the edge of the street where it will drain into an open ditch, storm drain system, or other drainage facilities that are available. See Figure 3 located on page 11. If no existing drains are available, then an excavation can be made at the outside of the street section and this excavation filled with drain rock. This will serve as a retention area for water produced in the system and an area to allow for percolation of this water into the surrounding ground.

Because local codes, soil conditions and weather conditions are unique to each location TSC will not specify a drainage system for a specific installation. The typical installations described in the following pages are provided as general guidelines and may not apply at your site location. Refer to the Design Engineer's drawing for the drainage system specified for your specific installation. If one has not been prepared, ask the Design Engineer to prepare one before proceeding with the installation. If you, or the design engineer, have any questions about the need for a drainage system, we urge you to contact the TSC Technical Support Center, toll- free, at 1-888-446-9255.

D. Base Can Installation – Core Drill and Saw Cut (Figure 1)

1. Remove the plywood base covers from the base can, mark them “Do Not Discard”, and store them in a safe location.
2. Begin the core drilling (typically 12 to 14 inch diameter, the depth will vary with terrain and/or suggestion of the civil engineer/contractor) and saw cut process. Holes should be drilled at fixture locations. Saw cuts should then be made to allow room for the fixture power cables (typically 3½” deep x ½” wide). Saw cuts are made parallel to the direction of the pedestrian travel and in line with the centers of the conduit holes.
3. In this installation, the base can fixture cable conduit holes will not be used with conduit. However, the fixture cables will pass from the edge of the saw cut into these holes. The cables will be held in place and the holes sealed with a sealing compound such as *Dollie Duct Seal* compound, or equivalent.
4. Prepare the drainage system specified by the design engineer. With this type of installation it is impractical to install a piped drain system. It is recommended that the modified French drain system be utilized. Refer to figure 1 on page 7.
5. Install the base can drain fittings provided into each base can drain hole. Run 1½ inch size pipe, Schedule 40 PVC, into the fittings of the base can. Pipe length should be cut so that the pipe, when positioned over the drain, extends approximately 3 to 4 inches into the drain rock.
6. Suspend the base cans so they are level with the surface of the pavement and supported so that they are rigid and won’t move during the concrete pour. Base cans should be oriented so that the fixture optics will be aligned parallel with the traffic lane. Use of mounting jigs is recommended for proper alignment of base cans. Consult the design plans for the preferred method of base can suspension for your installation.
7. Test the drainage system by pouring water into the base can at each fixture location before concrete is poured. Pour enough water to verify that the underlying ground is absorbing the water. If the base can is not draining properly, modifications to the drainage system will be necessary. In this case consult with your design engineer before proceeding. Once you’re satisfied that the drain is working properly, move on to the next step.
8. Install the fixture cables. Run fixture power cables to each base can, one black wire, one white wire for non-dimming fixtures. Run one black wire, one white wire and one green wire for dimming fixtures. If grounding is required by local code, run an additional grounding wire to each base can. The ground wire can be attached to the base can using the ground strap provided at the bottom inside of each base can.
9. Make sure that the filter fabric is in place above the drain rock to prevent slurry from clogging up the drain. Then encase the base cans and drainage system in concrete.

It is recommended that at least 6 inches of concrete be used below the base. Fill saw cuts with Traffic Loop Sealant, or equivalent.

10. After the concrete has hardened, remove the mounting jigs, clean out base cans, and replace protective plywood covers until fixtures are ready for installation.

Figure 1: Base Can Installation – Core Drill and Saw Cut

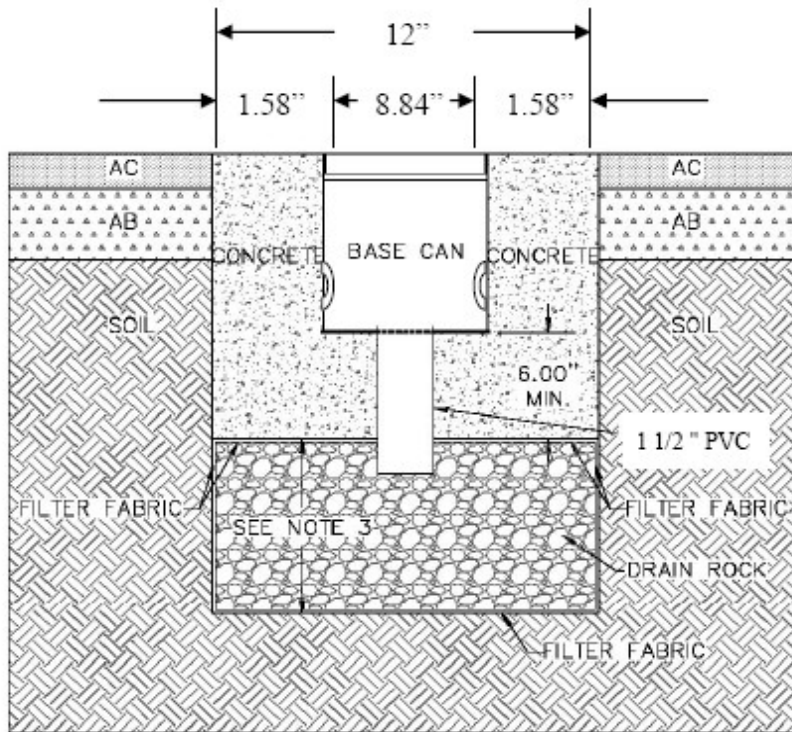

Drawing not to scale

Notes:

1. Drain rock shall be graded from 1 inch to ¼ inch.
2. Drain rock shall be encased in a filter fabric material to avoid soil infiltration into the drain rock.
3. Recommended depth of drain rock unit varies dependent upon the type of existing soils.
 - a. Where existing soils are granular and permeable the depth of the drain rock unit can be limited to 1 foot.
 - b. Where existing soils are fine graded and have low permeability the depth of the drain rock unit should be increased to 3 feet or greater to provide a reservoir for short term retention. Refer to engineering plans for the requirements specified by the project engineer.
4. Concrete shall be 3/8 inch maximum aggregate mix, use a minimum of seven sacks of cement per cubic yard of concrete and poured from a height of approximately 5 inches above the can. Concrete should only be poured from one side. Vibrate or rod concrete to completely fill the area below and on all sides of the base can. When concrete is visible on the side opposite to the side that concrete is being poured from, pouring can commence from alternate locations.
5. Abbreviations: Asphalt Concrete (AC), Aggregate Base (AB).

E. Base Can Installation – Trench and Fill – Option 1 (Figure 2)

1. Remove the plywood base covers from the base can, mark them "Do Not Discard", and store them in a safe location.
2. Begin trenching process. After trenching is completed along fixture locations, prepare the drainage system as specified by the design engineer. Refer to figure 2 on page 9.
3. Install the base can drain fittings provided into each base can drain hole. Run 1 1/2 inch size pipe, Schedule 40 PVC, into the fittings of the base can. Pipe length should be cut so that the pipe, when positioned over the drain, extends approximately 3 to 4 inches into the drain rock.
4. Suspend the base cans so they are level with the surface of the pavement and supported so that they are rigid and won't move during the concrete pour. Base cans should be oriented so that the fixture optics will be aligned parallel with the traffic lane. Use of mounting jigs is recommended for proper alignment of base cans. Consult the design plans for the preferred method of base can suspension for your installation.
5. Test the drainage system by pouring water into the supported base can at each fixture location. Pour enough water to verify that the underlying ground is absorbing the water. If the base can is not draining properly, modifications to the drainage system will be necessary. In this case consult with your design engineer before proceeding. Once you're satisfied, move on to the next step.
6. Install fixture cable conduit. Run 1 inch pipe size, Schedule 40 PVC, between each base can. PVC conduit should fit snugly into the grommets located at each base can conduit hole. Complete installation by running conduit from the last base can in the system to the system controller, as specified by the design engineer.
7. Install the fixture cables. Run fixture power cables through the conduit into each base can, one black wire and one white wire for non-dimming fixtures. Run one black, one white and one green wire for dimming fixtures. If grounding is required by local code, run an additional wire through the conduit to each base can. The ground wire can be attached to the base can using the ground strap provided at the bottom inside of each base can.
8. Make sure that the filter fabric is in place above the drain rock to prevent slurry from clogging up the drain. Then encase the base cans and drainage system in concrete. It is recommended that at least 6 inches of concrete be used below the base.
9. Backfill the trench with specified material, compact and cover per the designer's specifications, taking care not to damage conduit or drainage system. Remove mounting jig, clean out base can and replace protective plywood covers until fixtures are ready for installation.
10. After the concrete has hardened. Remove the mounting jigs, clean out base cans, and replace the protective plywood cover until fixtures are ready for installation.

Figure 2: Base Can Installation – Trench and Fill (Option 1)

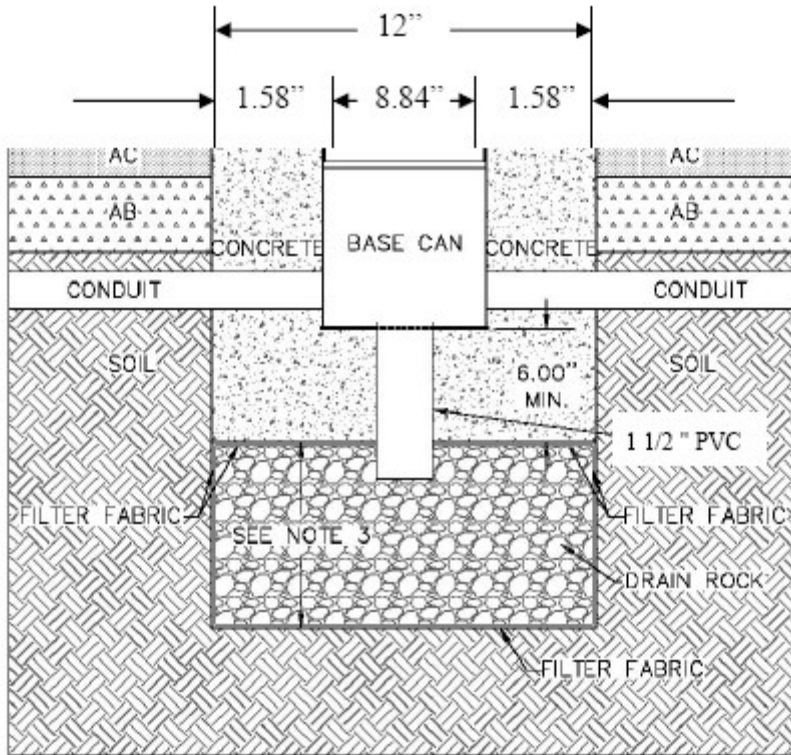

Notes:

1. Drain rock shall be graded from 1 inch to ¼ inch.
2. Drain rock shall be encased in a filter fabric material to avoid soil infiltration into the drain rock.
3. Recommended depth of drain rock unit varies dependent upon the type of existing soils.
4. Where existing soils are granular and permeable the depth of the drain rock unit can be limited to 1 foot.
 - a. Where existing soils are fine graded and have low permeability the depth of the drain rock unit should be increased to 3 feet or greater to provide a reservoir for short term retention. Refer to engineering plans for the requirements specified by the project engineer.
 - b. Concrete shall be 3/8 inch maximum aggregate mix, use a minimum of seven sacks of cement per cubic yard of concrete and poured from a height of approximately 5 inches above the can. Concrete should only be poured from one side. Vibrate or rod concrete to completely fill the area below and on all sides of the base can. When concrete is visible on the side opposite to the side that concrete is being poured from, pouring can commence from alternate locations.
5. Abbreviations: Asphalt Concrete (AC), Aggregate Base (AB)
6. **Note: Drawing not to scale.**

F. Base Can Installation – Trench and Fill – Option 2 (Figure 3)

1. Remove the plywood base covers from the base can, mark them “Do Not Discard”, and store them in a safe location.
2. Begin trenching process. After trenching is completed along fixture locations, prepare the drainage system as specified by the design engineer. Refer to Figure 3 on page 11.
3. Install the base can drain fittings provided into each base can drain hole. Suspend the base cans so that they are level with the surface of the pavement and aligned parallel with the traffic lane. Use of mounting jigs is recommended for proper alignment of base cans. Consult the design plans for the preferred method of base can suspension for your installation, making sure that they are rigid and won't move during the concrete pour.
4. Install drain conduit. Run 1 1/2", *Schedule 40 PVC*, from each base can fitting into the proper coupling (right angle bend, T-adapter, etc.). Connect all couplings together using the proper length PVC pipe. Run the end of the drain conduit into the drainage system, ditch, or leaching pit. The drainage conduit pipe should have a slight negative slope.
5. Test the drainage system by pouring water into the supported base can at each fixture location. Pour enough water to verify that the drainage system is absorbing the water. If the base can is not draining properly, modifications to the drainage system will be necessary. In this case consult with your design engineer before proceeding. Once satisfied move on to the next step.
6. Install fixture cable conduit. Run 1 inch pipe size, Schedule 40 PVC, between each base can. PVC conduit should fit snugly into the grommets located at each base can conduit hole. Complete installation by running conduit from the last base can in the system to the system controller, as specified by the design engineer.
7. Install the fixture cables. Run fixture power cables through the conduit into each base can, one black wire and one white wire for non-dimming fixtures. Run one black wire, one white wire and one green wire for dimming fixtures. If grounding is required by local code, run an additional wire through the conduit to each base can. The ground wire can be attached to the base can using the ground strap provided at the bottom inside of each base can.
8. Encase the base cans and drainage system in concrete. It is recommended that at least 6 inches of concrete be used below the base. After the concrete has hardened, remove the mounting jigs, clean out base cans, and replace the protective plywood covers until fixtures are ready for installation.
9. Backfill the trench with specified material, compact and cover per the designer's specifications, taking care not to damage conduit or drainage system.

Figure 3: Base Can Installation – Trench and Fill (Option 2)

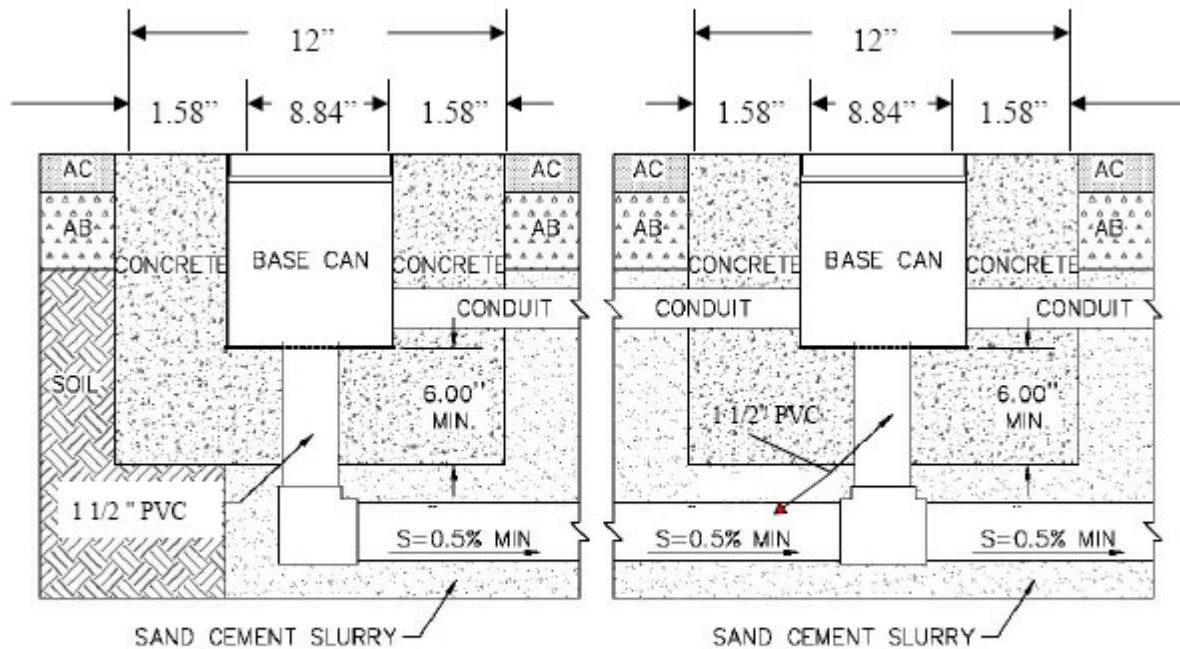

Notes:

1. The 1 1/2 inch PVC drain conduit is used to discharge water into the existing drainage system, existing ditches or if necessary a leaching pit.
2. The leaching pit can consist of a 36 inch diameter drilled hole carried to a depth of 6 to 10 feet and filled with drain rock.
3. Abbreviations: Asphalt Concrete (AC), Aggregate Base (AB), Slope (S).
4. Drainage slopes of 1% are typical.
5. Drawing not to scale.

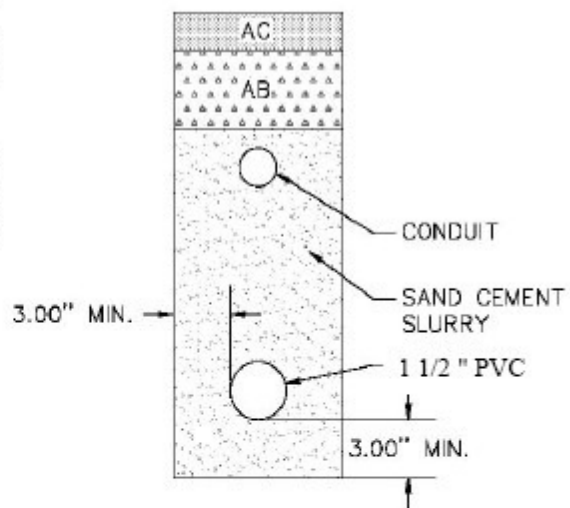

6. Concrete shall be 3/8 inch maximum aggregate mix, use a minimum of seven sacks of cement per cubic yard of concrete and poured from a height of approximately 5 inches above the can. Concrete should only be poured from one side. Vibrate or rod concrete to completely fill the area below and on all sides of the base can. When concrete is visible on the side opposite the side that concrete is being from, pouring can commence from alternate locations.

Section 3 – Electrical System Installation

A. Fixture Cabling

If the system is +12/24 VDC, then cable may be installed directly into saw cut 2½ inch minimum (typically 3½ inch) depth x 1/2 inch wide, instead of running the cable through conduit. Cable should be stacked into the saw cut, held down to the bottom using a backing rod and sealed using Bondo P606 or equivalent sealing compound. If using conduit pull cable through conduit. Ensure that all wiring conforms to NEC, State, Local and other applicable codes.

Note: Red wire may be substituted for White wire in DC circuits to reduce confusion between AC and DC circuits. Red wire will then be connected to the white lead wire on pigtail.

1) Fixtures

Using 10 AWG wire of appropriate type to meet local codes, pull one White (+12/24 VDC) and one Black (Return) power wire to each fixture (parallel circuit). If local code requires grounding, pull an additional green wire to each fixture.

Make a parallel circuit with 3M or similar waterproof connectors. At each fixture, using TSC's Part #CO-1051907021 pigtail connect the BLACK lead to the BLACK #10 AWG wire and connect the WHITE pigtail lead to the WHITE #10 AWG wire. The use of drip-loops is recommended.

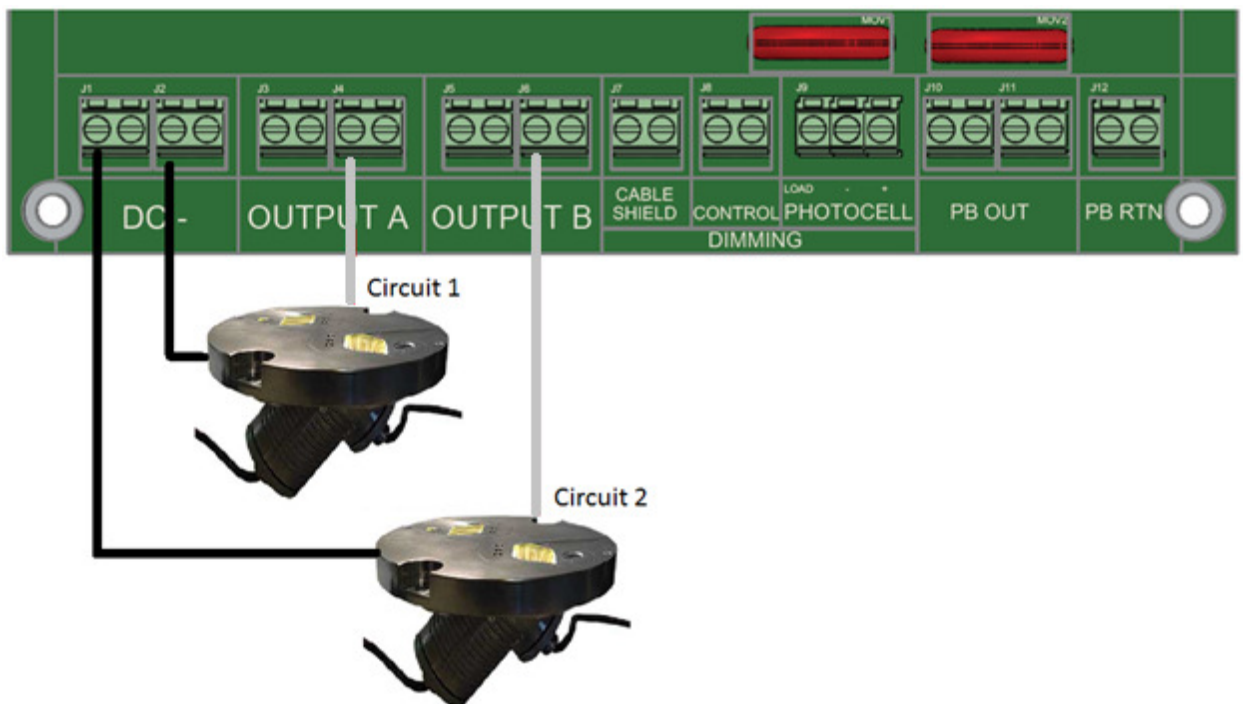

Wiring Diagram Non-Dimming Fixtures only

Note: Before proceeding to the next step check fixture cabling using the fixture cabling test in Appendix C, Section 2.

Note: Before inserting fixture into sockets, test each fixture using the test fixture socket and power plug cable supplied. The power plug connects to any standard 12 volt car accessory socket. Each fixture is tested by inserting its connector into the fixture socket.

B. Fixture Connections

1. Test each fixture using the fixture test cable supplied before inserting fixture into socket.
2. If heat shrink is provided or available use it to protect the connection of the pigtail connector and fixture plug. If heat shrink is not provided or available, use electrician's tape, make three wraps around the pigtail connector and fixture plug.
3. Prior to bolting down the fixtures, coat the mounting flange of each base can and bolt treads with marine grade anti-seize grease, like Corrosion Block or equivalent.
4. Bolt the fixtures to the base cans using the stainless steel bolts provided
5. Fill-in both, the area between the fixture and base can wall and the area in the bolt well, with a silicon sealant such as RTV silicon sealant, or equivalent.

C. System Controller Description

If your system shipped with a controller other than the TS1200, refer to its installation manual; otherwise use the installation instructions for the TS1200 Controller provided in this section. Refer to TSC wiring diagram provided with system. A description of the system, directions for installation and set-up are provided below. Troubleshooting guidelines are described in Appendix A.

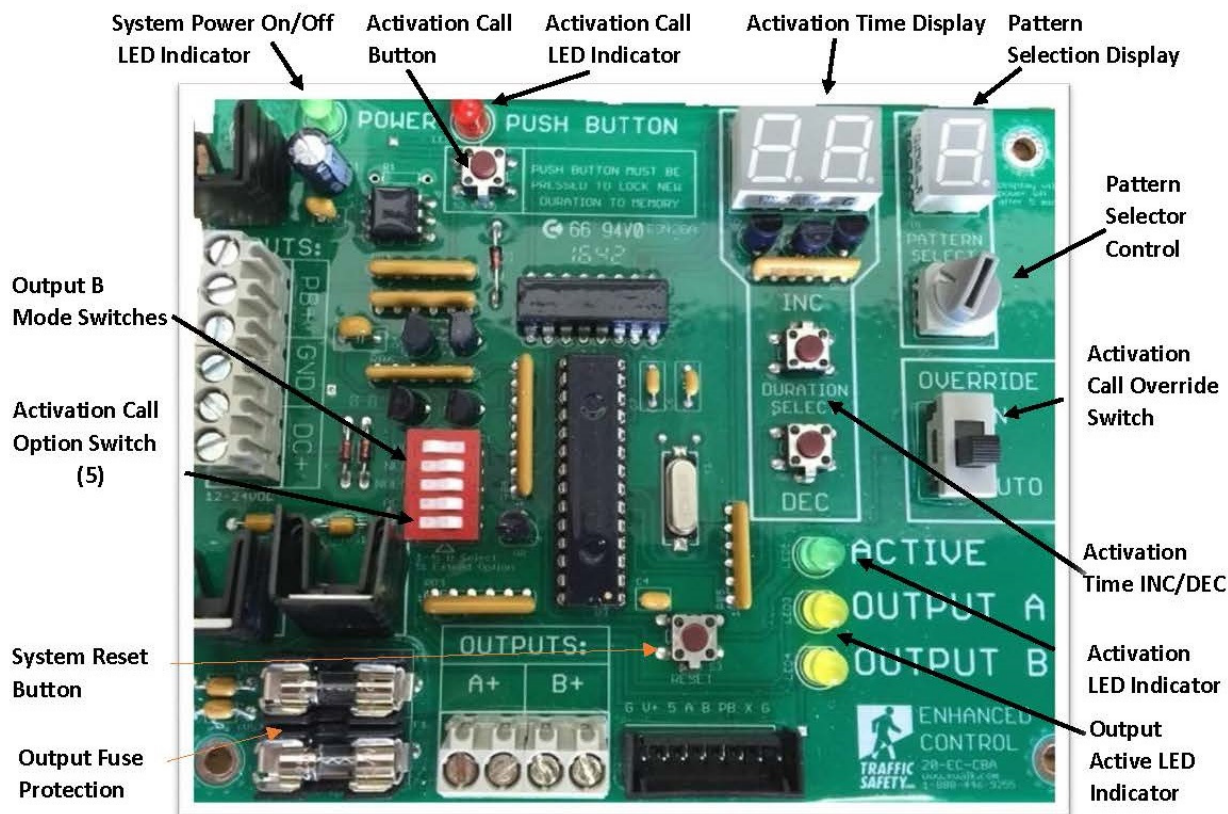

Enhanced Control Board

1. Pattern Selector – Flash pattern is selected by ten position pattern selector switch.
 - a. Position 0: 50 FPM Solid Flash Pattern (standard MUTCD flash pattern)
 - b. Position 1: 60 FPM Solid Flash Pattern (standard MUTCD flash pattern)
 - c. Position 2 – 8: Enhanced Flash Patterns (solid flash period is broken into a series of pulses)
 - d. Position 9: Rotates through each enhanced flash pattern, changing pattern each activation period.
2. Pattern Selection Display
 - a. Displays selected pattern option number (1 – 9).
3. Activation Time INC/DEC
 - a. Used to set activation time period. Activation time may be increased or decreased in one second increments over a range of one second to ninety-nine seconds.

4. Activation Time Display
 - a. Displays, digitally, the activation time in seconds over the range from one to ninety-nine seconds.
 - b. Pattern and time displays will dim after 5 minutes of inactivity to conserve power.

5. Output B Mode Switches

Output B pattern output is selected by the top four slide switches.

Note: C = CLOSED, O = OPEN

- a. Switch 1 (1=C, 2=O, 3=O, 4=O): Same flash period and pattern as Output A.
- b. Switch 2 (1=O, 2=C, 3=O, 4=O): Same flash period as Output A, but pattern is solid.
- c. Switch 3 (1=O, 2=O, 3=C, 4=O): Same flash period as Output A, but complementary duty cycle.
Pattern is not enhanced (solid pattern).
- d. Switch 4 (1=O, 2=O, 3=O, 4=C): Output B always active while output A is flashing.
- e. Switch 1-4 (1=O, 2=O, 3=O, 4=O): Output B always inactive.

Caution/Attention: Only one slide may be positioned in the CLOSED position at any given time. Having more than one switch positioned in the CLOSED position will result in improper system operation.

6. Activation Call Option Switch
 - a. Activation call option is selected by the bottom slide switch, Switch #5. When closed, allows activation period to be reset by activation call. When open, ignores activation calls during the activation period (does not reset and begin the activation cycle).
7. Activation Call Override Switch
 - a. When switch is in AUTO position (normal operation), allows activation call to initiate activation period.
 - b. When switch is in ON position, allows continuous flashing during periods of continuous pedestrian traffic (activation calls are not required to activate system).
8. System Power On/Off LED Indicator
 - a. LED on when power is applied to the system.
9. Activation Call Button
 - a. Sends activation call to initiate activation flash periods.
10. Activation Call LED Indicator
 - a. Flashes when activation call is sent from activation call button.
11. Activation LED Indicator
 - a. On during activation period.
12. Output Active LED Indicators
 - a. Indicate the flash pattern being sent to Output A and Output B.
13. System Reset
 - a. Resets the control board.

D. System Controller Installation

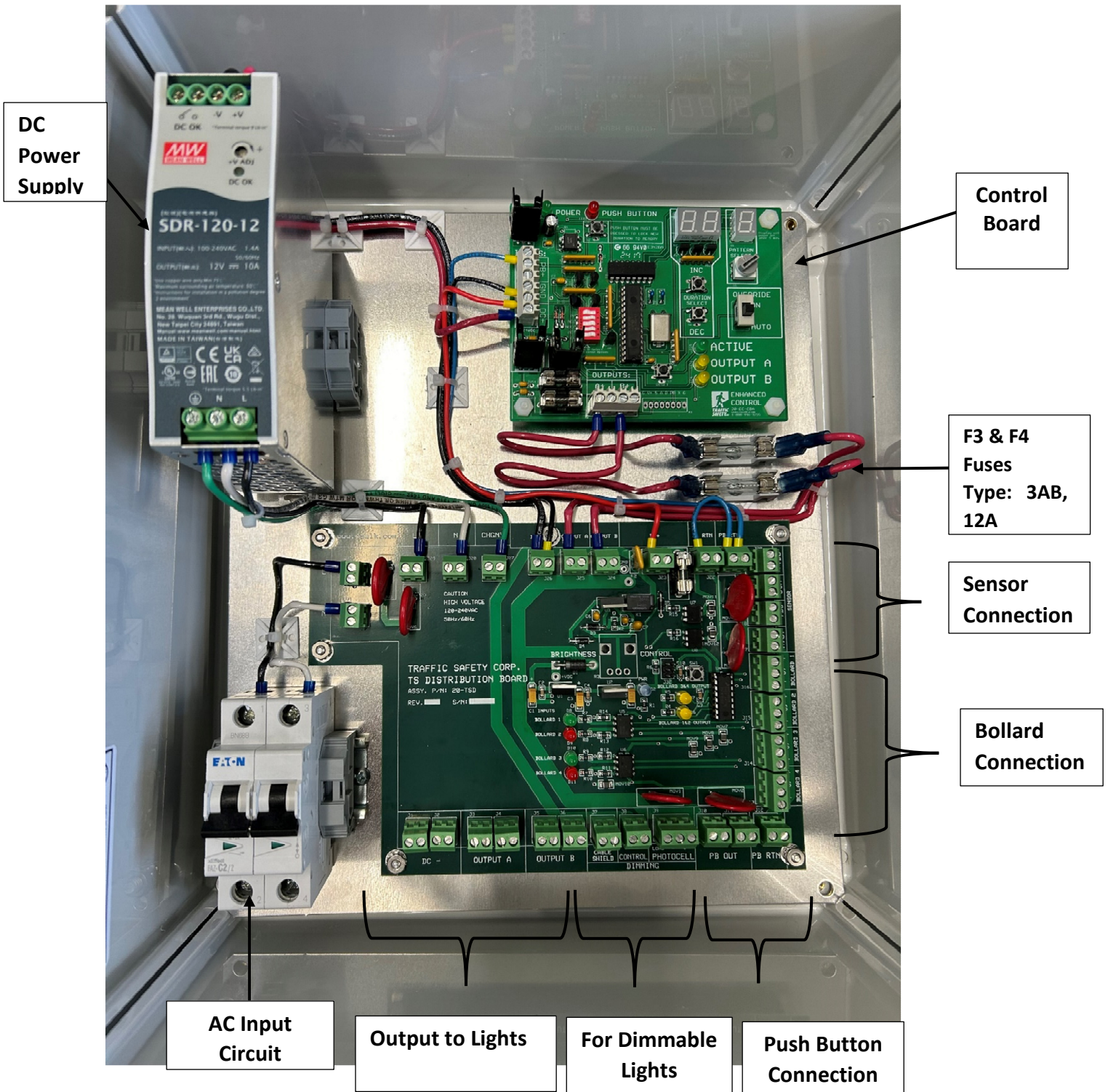

1. Mount control system in its proper location, as specified in the design plans.
2. It is recommended to place two holes in the bottom of the enclosure for 1 inch conduit fittings, one for incoming power and one for the output. The recommended hole locations are shown below. Fittings must be UL Listed and of suitable type and rating to maintain water tightness of the enclosure.

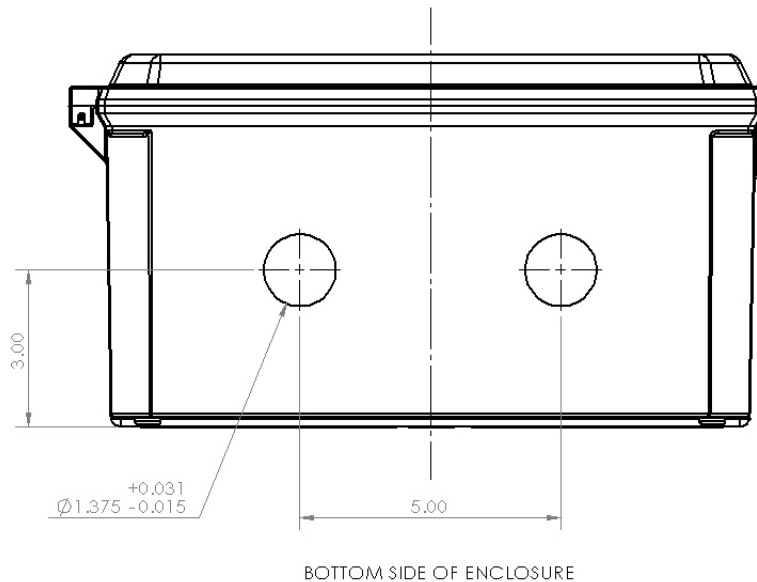

3. Make sure that the devices provided are rated for the output voltage level of the control system.

Caution/Attention: Devices are specifically matched to the output voltage level of the control system. Use of any other type or quantity of fixtures may damage the control system, fixtures or both.

4. Set the circuit breaker to OFF position.

Caution/Attention: Always ensure the system circuit breaker is in the OFF position before servicing the system wiring.

5. Connect the AC green ground wire to AC Input Ground, Green Terminal, as required by local code.
6. To provide maximum protection from surges, ensure that the system ground is tested and provides less than 25 ohms to ground resistance.
7. Connect the 120/240VAC source wiring to the Input circuit breaker. Connect the Line to the left side of the breaker marked "L". Connect the Neutral or Line 2 to the right side of the breaker marked "N".

8. Before connecting output circuits to controller, set the circuit breaker to the ON position and power up the TS1200. Verify that control board powers up and all indicators appear normal. Press the Activation Call Button on the control board to check for proper system response. If all is well, set the circuit breaker to the OFF position and proceed to the next step.

9. Connect the fixtures parallel circuit wiring to Output A. White (DC+) wire to OUTPUT A (+12 VDC) and black wire to DC - terminal. Note the following:

- On 12 VDC models the power output of A is 120 Watt maximum on Output A.

Note: Red wire may be substituted for white wire in DC circuits to reduce confusion between AC and DC circuits. Wire is connected to red terminal block contact.

10. Connect the secondary fixture, sign or beacon parallel circuits to Output B. White (DC+) wire to OUTPUT B (+12 VDC) and black wire to DC - terminal. Note the following:

- On 12 VDC models, 120 watt maximum on Output B
- On 12 VDC models the combined power output of A plus B is 120 watt maximum.**
- When connecting signs and beacons, ensure Output B mode is compatible with the flashing capability of the load device (See Output B Mode Switches Setting Above).

11. If using Shielded Cable, connect the drain wire to the Cable Shield connector J7, at the bottom of the distribution board.

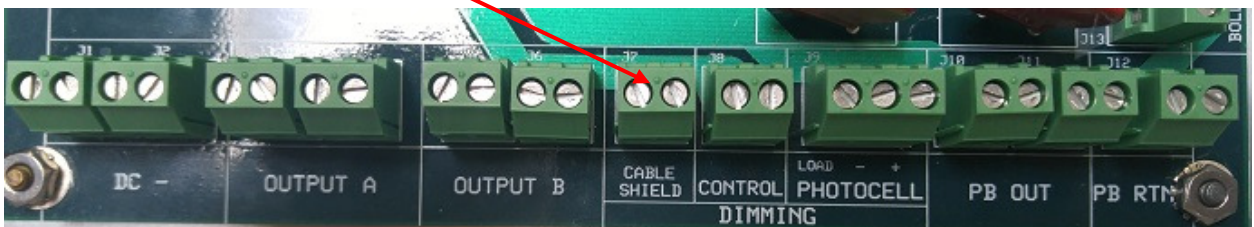

For wiring diagrams and instructions for each specific activation option see the following section.

12. Before continuing, perform a check on the DC loads:

- Ensure that DC loads are not connected to the 120 VAC input terminals.
- Set the circuit breaker to the ON position and test the operation of the DC loads before continuing.
- Set the circuit breaker to the OFF position.

Caution/Attention: Ensure DC load circuits are connected to DC output terminals and AC input power to AC input terminals. DC loads connected to AC terminals will damage the load device and wiring.

13. Ensure all wiring conforms to local code.
14. Set the circuit breaker to ON position and test system operation.
15. Refer to Appendix A for trouble shooting guidelines.

E. Wiring and Operation of Activation Options

1. Push-Button

When the switch is activated, a beep will be heard and the LED will flash (Momentary Mode) or will light and stay on until the walk cycle (Latching Mode).

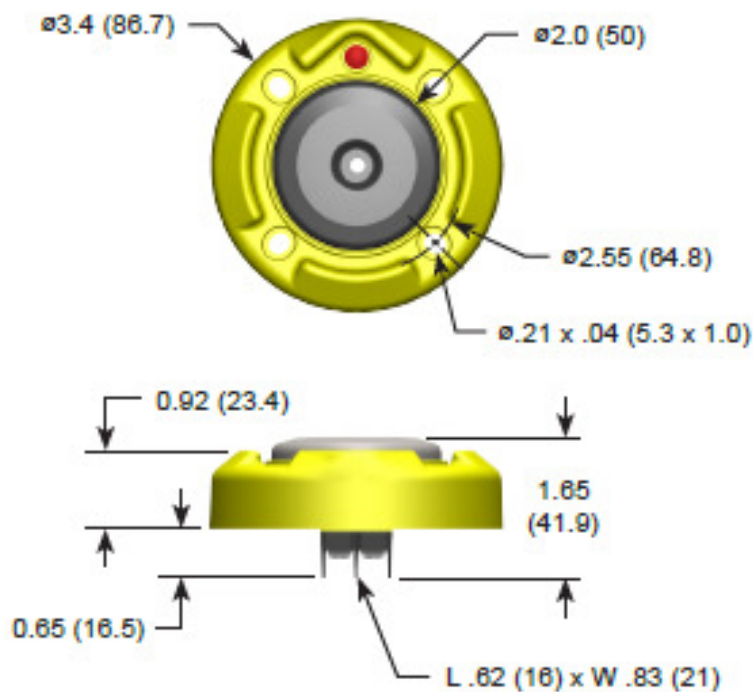

Body Material: Aluminum, Powder Coated

Button Material: 316 Stainless Steel

Arrow Button Material: Anodized 6061 Aluminum, Nickel Plated Black Powder Coat on area surrounding arrow

Operation Voltage: 12-36VDC

BDL3 Push Button

Push Button comes with Aluminum Push Button Cup

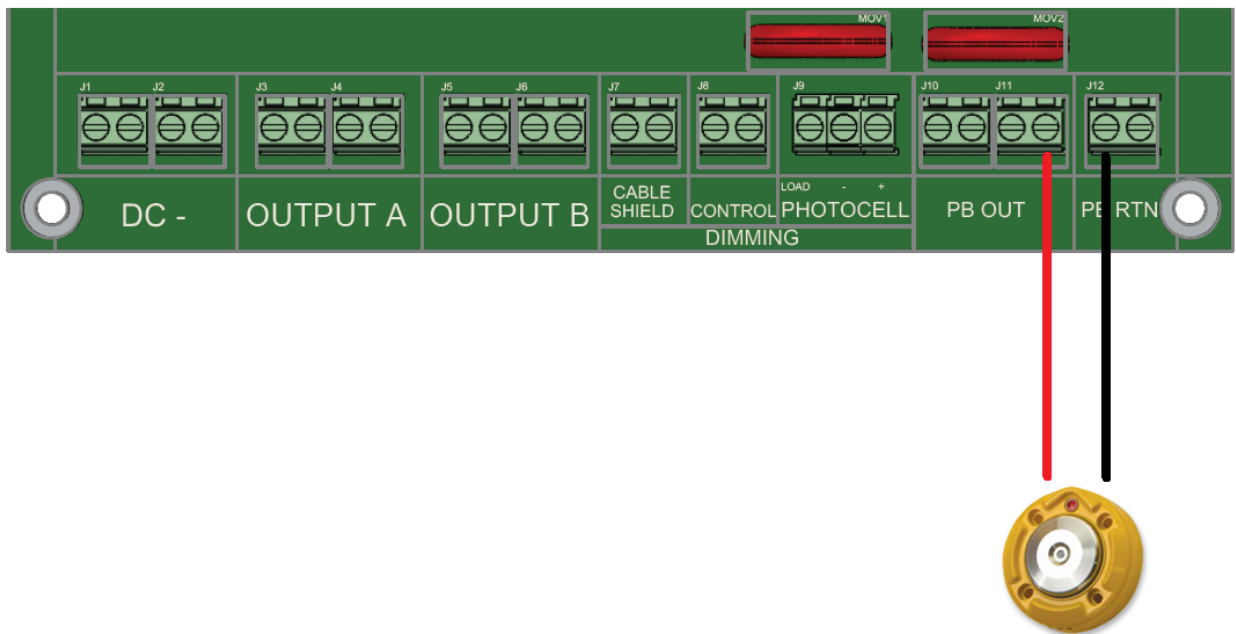
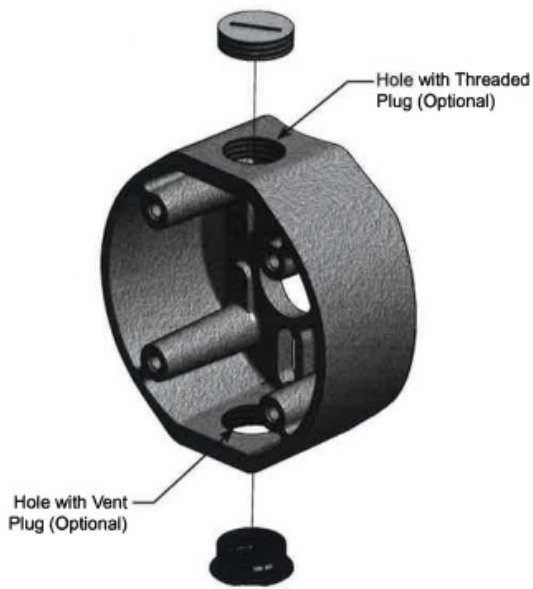

Wiring Diagram for Bulldog III Push Buttons

2. Photo-Sensor Bollards

The Traffic Safety Corp. Photo-Sensor Bollards is a passive detection device used to trigger in-pavement crosswalk lights or LED pedestrian signs. When a pedestrian enters the crosswalk between the bollards, an infrared beam is broken and the system generates an activation in the

form of a relay contact closure, or 12-24VDC momentary signal. The system is directional, meaning an activation only occurs when the pedestrian enters the crosswalk, not when exiting.

It is recommended to install the bollards using ½" L-Hook concrete anchors installed in newly poured level concrete. The site engineer should evaluate the installation method to verify adherence to local codes.

The front of the bollards should be directly facing each other, not skewed or offset. The sensor can be adjusted during the aiming process, but proper installation is crucial in order to facilitate calibrating the sensor.

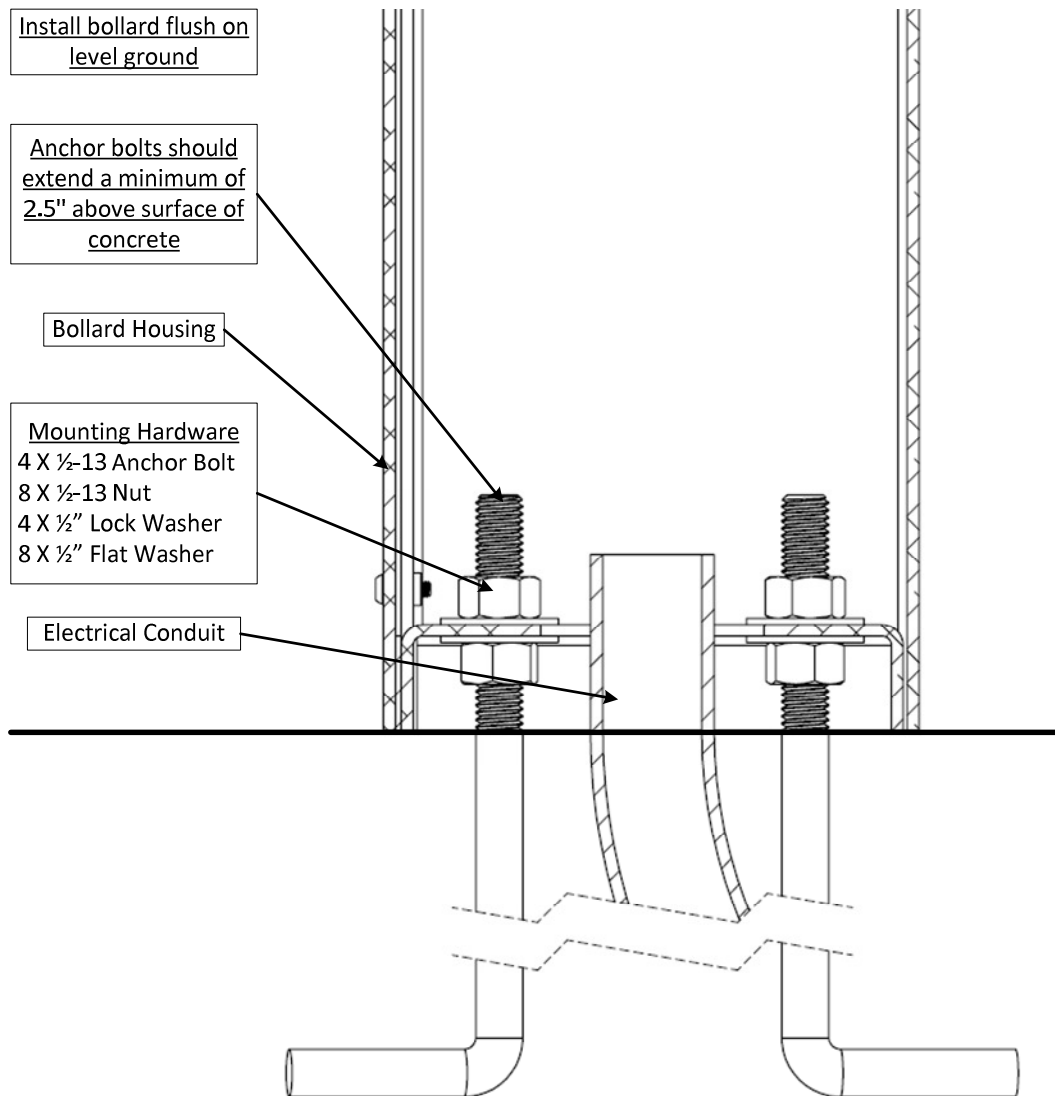

ALIGNMENT AND OPERATION

In order for proper operation, the sensors in each bollard must be properly aligned. When the sensors are optimally aligned the green LED and orange LED on the receiver will be illuminated. When the beam is blocked or the sensor is misaligned, the amber LED will be illuminated.

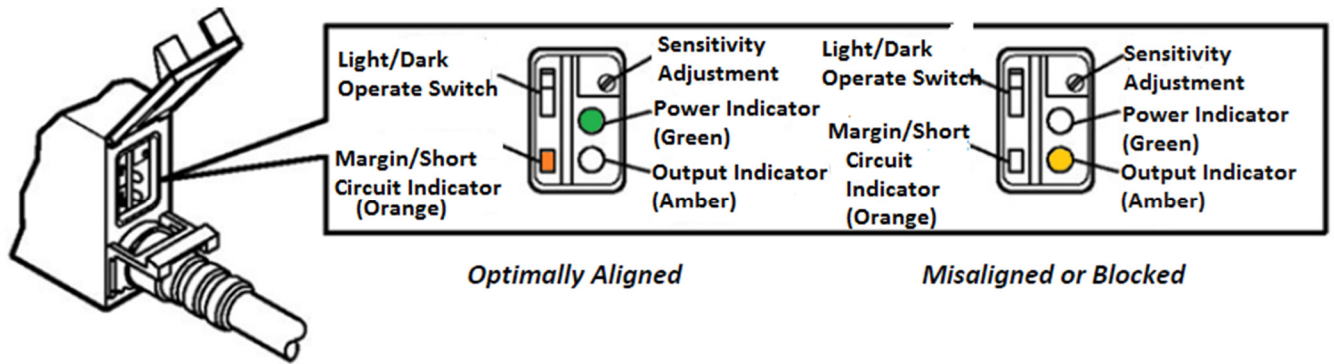
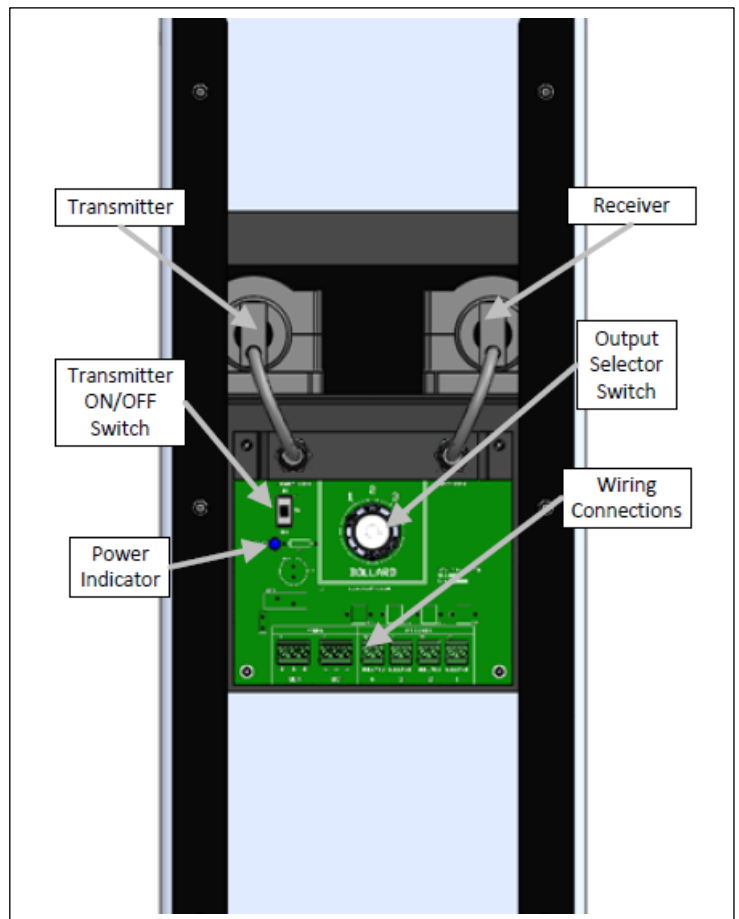

Figure 42: Sensor Status Indicators

When viewing the bollard from the rear, the receiver is on the right hand side. There is a slide switch located on the circuit board below the transmitter. This switch controls the power to the transmitter. It is best to have the transmitter turned off when aligning the receiver in the same bollard. Follow the bellow steps to align each bollard.

- Have one person stand at the first bollard and watch the LEDs on the receiver.
- Turn off the transmitter of the first bollard.
- Have a second person at the corresponding bollard loosen the screws on the transmitter swivel mount.
- Aim the transmitter using small adjustments until the receiver in the first bollard shows proper alignment.
- Tighten the swivel mount screws.
- Turn the first bollard transmitter back on.
- Repeat steps for each bollard.



Misalignment Indication:

Once the bollards are aligned, they operate accordingly while in their set position. The TS1200 controller has a safety feature that will enable the lights, 5 minutes after one or more bollards have been misaligned.

If the lights are constantly flashing, this is an indication that one or more bollard units have been shifted.

The lights will not turn off until the bollard's position is adjusted.

The controller's board, shown in the below picture, has two sets of LED lights. The LED light will turn on for the set of bollard that was shifted.

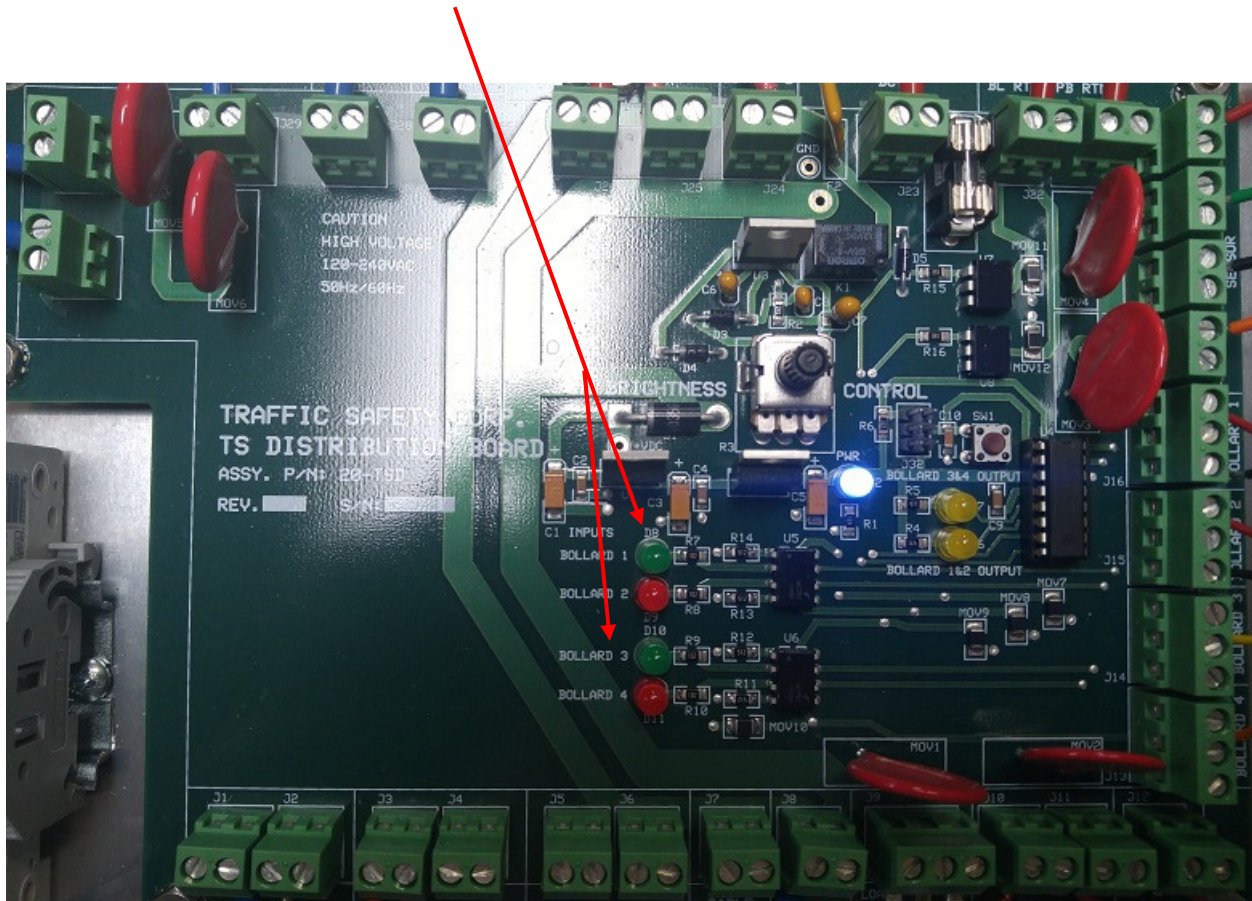
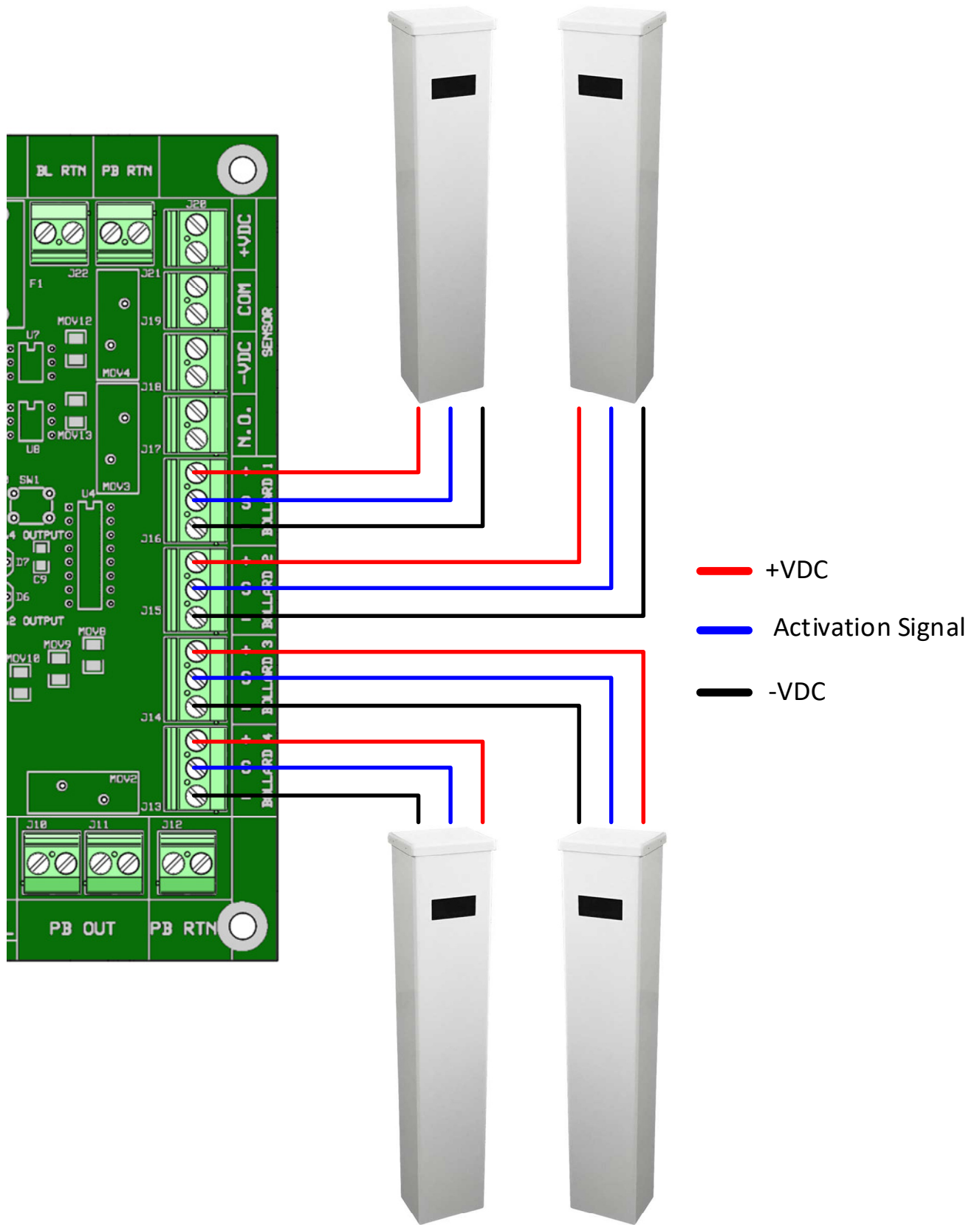
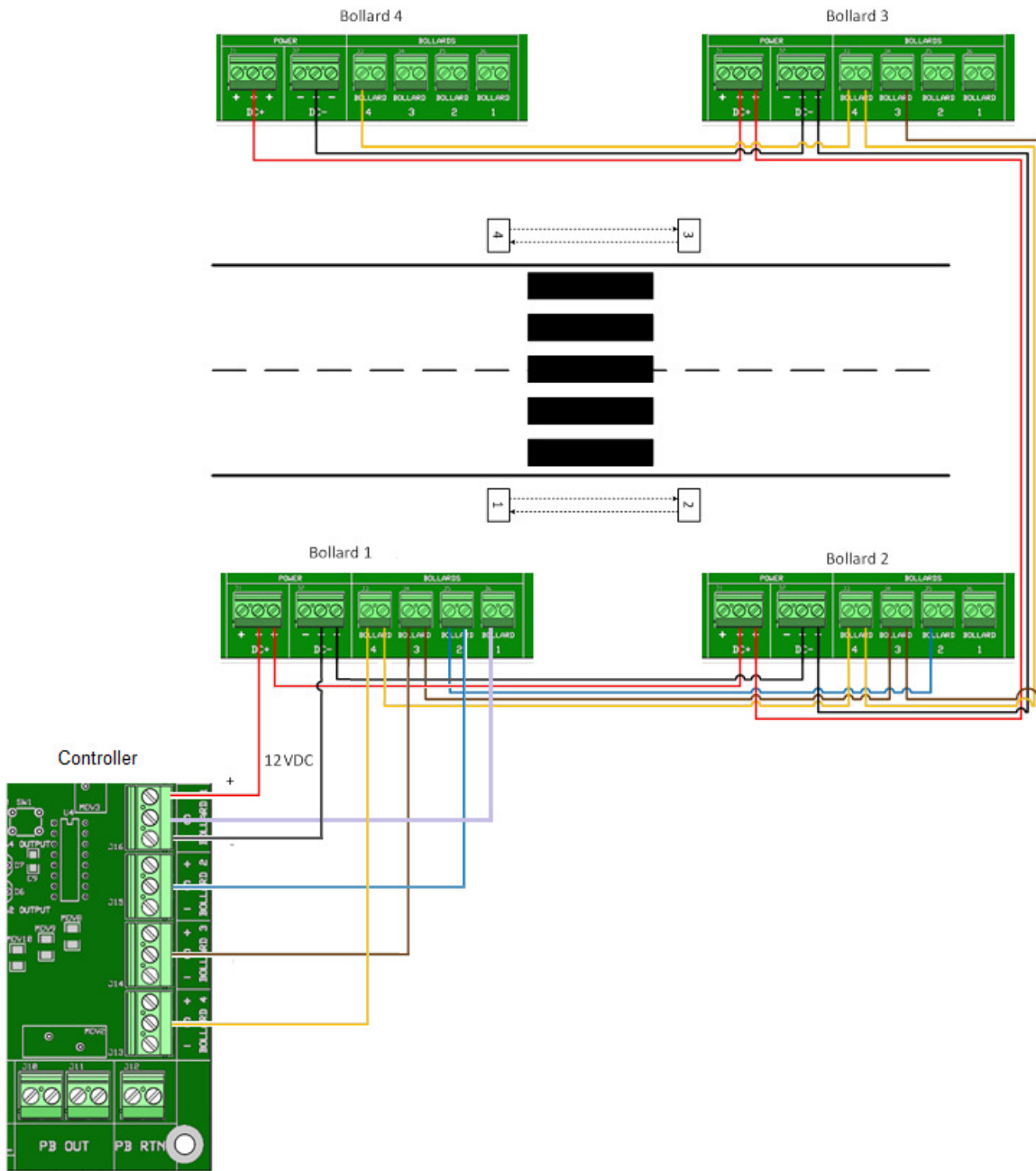

Image 2



Wiring Diagram for Photo-Sensor Bollards Activation (OPTION 1)



Wiring Diagram for Photo-Sensor Bollards Activation (OPTION 2)

3. TCB26-B Vehicle Sensor

The Model TC26-B is a microprocessor controlled vehicle sensor with a variable range. It is designed to trigger the operation of a traffic controller. The TC26-B will only respond to motion in one direction (approach or depart only-selectable), which makes it ideal for long-range detection at intersections. A microprocessor analyzes the reflected microwave energy and responds to motion in the proper direction. The TC26-B generates an extremely low power microwave beam aimed to cover the same area normally covered by a loop detector system.

The TC26-B operates on much the same principle that police radar uses. The unit transmits a low power microwave signal, some of which is reflected by a moving target, such as an automobile or truck.

The TC26-B will perform best when is aimed directly at traffic. This can be accomplished by mounting the unit at the typical mounting height of 14' to 24' and aiming the sensing head so it can "view" the traffic coming toward or moving away from the unit.

Side-Fire mounting is also acceptable.

The TC26-B is mounted with 2 lag bolts through 2-1/2" prepunched mounting holes, or by banding to the poles.

To remove the fastening bracket from the sensor, take out the 5/16-18 horizontal bolt holding the bracket to the hinge. Using the bracket as a template for locating screw holes, mark and drill the pole or band the bracket and refasten the sensor to the bracket with the 5/16-18 bolt removed earlier.

See the wiring diagram on the next page and TC26-B additional installation instructions that were shipped with the system for more specifications.

F. System Controller Setup Instructions

1. Refer to design engineer's set-up requirements for the installation.
2. Set desired pattern using the Pattern Selection Control and Display (Typically in position 9).
3. Set activation period using the INC/DEC push-buttons and Activation Time Display.
4. Set the Output B mode using the four Output B Mode Switches (Typically set to OOCO).
5. Set the activation call option using the Activation Call Option Switch (Typically set to C).
6. Set the activation call override switch to auto, for normal mode, or on for continuous flashing mode (Typically set to Auto).
7. System should now be ready for final testing. Press the Activation Call Button to send a call and monitor the fixtures and other warning devices for proper operation.

Section 4 – Maintenance

A. Fixtures

Fixtures are made from corrosion resistant anodized aluminum or corrosion resistant stainless steel that can withstand salt and other chemicals. Fixtures are rated to withstand static loads up to 44,000 lbs. without sustaining permanent deformation or cracking of materials. Leads and gaskets are rated to withstand up to 300 degrees F. Under normal conditions no maintenance is required except to periodically check the integrity of the drainage system, periodic cleaning of the lenses and occasional factory replacement of the LED lamp.

B. Base Cans

Traffic Safety fixtures are designed for minimum field maintenance. If properly installed, fixtures should not require any maintenance. Fixtures subjected to standing water in the base cans for long periods of time will eventually take in water, resulting in an electrical short and damage to the fixture. Furthermore, standing water in the base can that is subject to cold temperatures may damage the base can, fixture and, or connectors due to repeated expansion and contraction of the water as it freezes and melts. As part of a maintenance program, fixtures should be checked every six months to ensure the integrity of the drainage system. Any standing water should be removed immediately.

C. Lenses

The TS400, TS500 and TS600 series fixtures all feature a self-cleaning lens design. If the fixtures are installed properly cleaning will not be required for long periods of time. If needed, lens cleaning can be done periodically using pressure or hand washing.

D. LED Lamp Replacement

The long lasting LED arrays have an estimated ten year average life expectancy. In order to keep the fixture warranty in effect all LED lamp replacements are serviced at the TSC facility. At our facility we complete a comprehensive inspection and evaluation of the fixture; replace the LED unit(s), replace the sealing components, gaskets and, or O-Rings; verify the seal and burn-in the LED unit(s). A process is in place to make the lamp replacement easy for our customers. Once a request is received, a refurbished replacement fixture is immediately sent out with a return tag. When the customer's fixture is received it will be evaluated. If repairs are covered by the warranty the customer will receive a full credit for the fixture. If repairs are not covered by the warranty or the fixture is out of warranty, the customer will be credited for the return minus the cost of the replacement service.

Appendix A – TS1200 Troubleshooting Guidelines

The TS1200 controller includes several indicators and controls to assist the installer in the troubleshooting process. Recommended equipment required for trouble shooting:

Narrow slotted screwdriver
AC/DC multi-meter

When performing maintenance on the TS1200 be aware of the following safety considerations:

All measurements suggested should be made on terminals with wires in place. Do not remove any wires.

Exposing the DC side of the circuit to AC voltage can damage the controller as well as attached devices.

The Circuit breaker should be in the OFF position when making any wiring changes.

These troubleshooting steps are intended to be performed in sequence. When a problem is detected, verify all troubleshooting steps starting from Step 1.

Symptom	Problem	Check
System not functional 1. No indicator LEDs are lit 2. System does not respond to any inputs.	NO AC power to control board	1. Check Circuit Breaker is in ON position 2. Check Input AC voltage level 3. Check AC voltage level at input to power supply 4. Check that all terminal block screws are tight and wires are secured.
	Power Supply not functioning	1. Check AC voltage level at input to power supply 2. Check to see that DC power LED is ON. a. If ON but dim, immediately disable AC power to system and check for shorts. 3. Check DC output voltage (should be between 12-14 VDC for 12Volt systems). a. If low voltage is read, system may be shorted or overloaded. Disconnect all output loads and recheck voltage level. b. Power Supply may be damaged. Replace power supply.
Control board not functional: 1. Power LED on control board not lit. 2. No response to any inputs	Control board not functioning	1. Check that red and black wires into control board are secure. Measure voltage between DC and GND input terminals. 2. Push reset button, display should activate. 3. Inspect board visually for visible damage. 4. Replace control board.
System does not activate. 1. Activation device does not initiate output.	Inoperable activation device or control board	1. Check all wiring connections to activation device. 2. Check that "Push Button" indicator lights when activation device is triggered: a. If indicator lights, but system does not activate, replace control board. b. In indicator does not light, check activation device connections. Note: PB1 is DC+ when measured to ground.

Output B does not operate as intended.	Output B dip switches incorrectly set.	<ol style="list-style-type: none"> 1. Check dip switches 1-4 on control board. Only one switch should be ON at a time.
<p>Output A or Output B does not match the Output A or Output B status LED.</p> <ol style="list-style-type: none"> 1. Output may be stuck in ON or OFF mode. 2. Output may be dim or flickering 	Blown fuse	<ol style="list-style-type: none"> 1. Check glass fuse on control board. A break could be difficult to see. Check with a multi-meter if unsure. If blown, replace with a 2AG Type, 12 Amp fuse. If fuse continues to blow, check load for shorts or overloading. Note: Top fuse is for Output B, and bottom fuse is for Output A. 2. If fuse slightly glows or pulses with the output, but does not blow out, the output load may still be overloaded or shorted.
	Wiring issue	<ol style="list-style-type: none"> 1. Disconnect Loads and verify operation with a multi-meter on the output terminal block. 2. Check that output wires from control board and into output terminal block are secure. 3. Verify load circuit is operational by temporarily connecting the positive lead of the load circuit to PB1, load should operate. <ol style="list-style-type: none"> a. Immediately disconnect load if issue persists and correct problem in load circuit.
	Control board not functioning	<ol style="list-style-type: none"> 1. With load disconnected and override switch set to ON, test output voltage on the control board of each output (A+ and B+) with respect to GND. If: <ol style="list-style-type: none"> a) Output is stuck OFF, measure on left side of output fuse for voltage, to verify fuse is not faulty. b) Output is stuck ON. Verify Output B dip switches are set correctly. c) Otherwise, output circuit on control board is inoperable. Replace control board.
Lights are constantly on	Bollards may be misalign	Align the bollards to their initial position. See the controller's board for LED signal indication of the misaligned bollards.
	Obstruction on the bollard's sensor window	Clear obstruction

Appendix B – TS1200 Component Replacement List

12 VDC Power Supply
Enhanced Control Card
12 Amp Fuse, 2 AG Type

Appendix C – Fixture Cabling Test

Note: The "Fixture Cabling Test" must be performed before (1) Any of the fixture plugs are plugged into fixture socket(s); and (2) The cabling coming from the fixture sockets is connected to the controller output connector terminals.

After the fixture socket pigtails are spliced onto the cabling inside of each base can, and the cabling coming from the fixture sockets is routed to the controller location, perform the following steps:

1. Connect one side of an ohm meter to the white wire located at the base of the controller enclosure. This connection will remain in place until the test is completed. The wire used for this connection must be long enough to reach all of the fixture locations (base cans).
2. Starting from the base can located closest to the controller, connect the other probe of the ohm meter to the contact point of the fixture socket with the largest inside diameter. A low resistance reading indicates a correctly wired fixture socket. If a high resistance reading is indicated (meg-ohms) the wiring in the fixture socket is incorrect and needs to be reversed, or the wiring between the fixture socket and controller location is open. To determine which the case is, connect the ohm meter probe to the contact point of the fixture socket with the smallest inside diameter. A low reading confirms that the socket wiring needs to be reversed. In this case reverse the wiring connections in the socket at the pigtail splice point. A high reading indicates that the wiring is open between the controller and the fixture socket. In this case the cabling between the two points (Controller and base can or between the last base can and the current base can) may not be properly connected, or the cable between these two points may be defective. Before replacing the cable the fixture socket pigtail splice should be visually examined for continuity.
3. Repeat step 2 for each base can in the system, moving from the closest base cans to the one located furthest from the controller.

Appendix D – Limited System and Product Warranties

1- Year Limited Product Warranty

For all products manufactured by TSC, but not purchased as part of a complete system, TSC provides a 1-year limited product warranty which warrants them to be free of material defects for a period of one year from the date of shipment. Warranty Limitations TSC makes no warranties, express or implied, other than those stated herein. For example, TSC does not warranty the workmanship of the installer, damage caused by acts of nature, vandalism, improper installation, improper maintenance or abuse. Note: The warranty period of fixtures covered under the 5-year system warranty is reduced to two years when fixtures are subjected to abrasive materials or chemicals. TSC is not an engineering firm and makes no expressed or implied warranty as to the applicability of its products or systems in any specific situation, applications or location: such decisions are the responsibility of the owner, designer engineer and/or others. Therefore, as to all goods sold by TSC, TSC hereby disclaims any implied warranty of merchantability or implied warranty of fitness for a particular purpose and Buyer agrees that TSC shall not be liable for any special, indirect, incidental, consequential or liquidated damages of any kind whether the Buyer's or any other claim is based upon contract, tort or any other legal theory.

5-Year Limited System Warranty

TSC supplies fully integrated and factory tested in-roadway warning lighting systems. TSC's systems are backed by a 5-year limited system warranty on all core components of the system purchased from and integrated by TSC. Core components are defined as the system controller, fixtures, base cans, fixture connectors, LED signs, and activation devices that are set forth in the TSC Price Book. The warranty excludes any components not purchased from TSC including, but not limited to, signs, beacons, lamps, batteries, solar panels, and activations devices. To avoid invalidating the TSC 5-year limited system warranty all components of the system connected to the system controller must be listed on the Submittal Form and approved by TSC for connection to the system controller. Adding components not listed on the Submittal Form voids the 5-year system warranty and the 1-year product warranty on the system controller. System components that are integrated in to the system, but not purchased from TSC, are excluded from the 5-year system warranty and 1-year product warranty. Core components covered by the system warranty are warranted to be free of material defect for a period of five years from the date of shipment.

Appendix E – Core Drill and Saw Cut Installation Pictures



Fixture Layout



Core Drill



Saw Cut



Drainage



Mounting Jig Setup



Base Can Alignment



Base Can in Concrete



Plywood Protective Cover



Fixtures Placed In Base Cans



**TRAFFIC
SAFETY** CORP.
www.xwalk.com

Traffic Safety Corporation
2708 47th Ave.
Sacramento, CA 95822