

TS-SR-45C

Uni-directional, Stainless Steel LED Road Stud

General Description

Our TS-SR-45C stainless steel road stud features a durable, low maintenance design with outstanding visibility during the day and at night.

The TS-SR-45C is typically used in crosswalk applications, but it also can be used to mark school zones and rail-road crossings, lane control for bridges and tunnels, wrong way warning, and toll booth or toll way lead-on applications.

All In-Roadway Warning Lighting System components are available from TSC. A typical installation would include a set of road studs, a control system, one or more activation devices such as a pedestrian push button station, and flashing LED crossing signs.

Features

- Robust construction, suitable for harsh conditions (salt, chemicals and weather exposure)
- Snowplow resistant
- Low maintenance, 100% waterproof
- Silicone-free junction sealing technology allows better, faster and cleaner maintenance
- IP68/IK10 Compliant
- High mechanical resistance: up to 120 tons, suitable for regular traffic areas of heavy vehicles
- Outstanding visibility during the day and at night
- Up to .62 mile (1 km) visibility distance due to high intensity LEDs
- Suitable for applications in crosswalks, school zones, bridges and tunnels
- Only .34" (8.6mm) above road surface
- Connect multiple road studs in series circuit
- Installation accessory for easy leveling
- Easy replacement: base (fixed in the pavement), main body (removable)
- LEDs protected by polycarbonate window
- Optional: use different LED colors in each window

Specifications

Modes of Operation

- Steady (other modes of operation like flashing or sequential are available with external controller)

LED Configuration

- Uni-directional



Electrical Features

- Power Supply: 12V/24V DC
- Max. Current Consumption: 80mA
- Power Cable: Brown (+) | Blue (-)
- Cable Section: 2 x 0.75mm
- Operation Temperature: -13°F to +185°F (-25°C to +85°C)

Optical Features

- LED Quantity: 8 LEDs
- LED Type: 5mm
- LED Colors: White, Red, Amber, Green, Blue
- LED Viewing Angle: 15°
- LED Life Span: 100,000 hours (manufacturer specification)

Mechanical Features

- Top Material: Hard stainless steel league with good corrosion resistance and polycarbonate window certified to UL 94 V0
- Bottom Material: Aluminum
- Weight: 6.6 lb. (3 kg)
- Rising from Surface: .34" (8.6mm)
- Mechanical Resistance: up to 120 tons
- Dimensions: Ø6.3" (160mm) x 3.49" (88.6mm)
- Protection Index: IP68 / IK10

Applications

- Heavy traffic zones, snow areas, road delineation, crosswalks, among other applications

Installation Manual

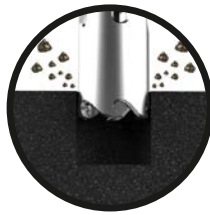
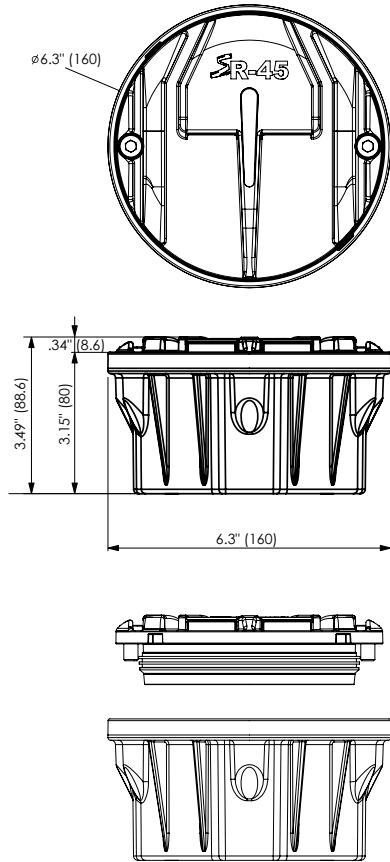

After deciding the location where the stud will be installed, drill a hole having a minimum diameter of 6.5" (165mm) and minimum of 3.5" (90mm) deep.



Using a disk cutter, open a connection between the holes with .59" (15mm) width and 2.36" (60mm) depth.



Brush any debris or dust from the hole resulting from drilling.



Dry the hole with a blowtorch to remove any moisture that may compromise the adhesion and effectiveness of the glue.

Installation Accessory - SR-SFT4

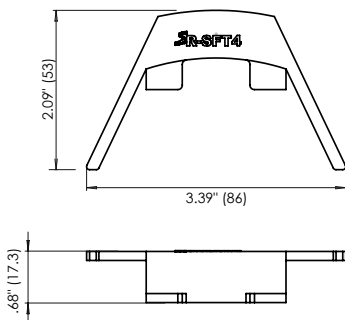

Apply the installation accessory in each road stud that will be installed. The accessory will help align and keep the road stud in place during the glue drying time. This accessory will be removed at the end of the installation.



Pour ±5.5 lb. (±2.5 kg) of glue SikaFlow-648 in the hole and insert the stud. Remove any excess glue. Alternative glues: FAPLISA F-3976, FAPLISA F-3096R, TRIFLEX CRYL R 238

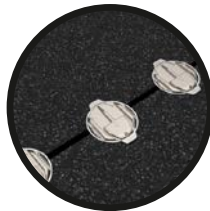

The glue drying time may change depending on weather conditions. Consult the glue data sheet for more information. After the glue has dried, the top part of the installation accessory should be broken and removed.

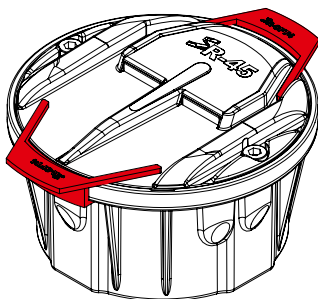

Changing or not completing the described installation process can result in suspension of warranty. Personal protective equipment must be worn during installation.

Ordering Information

Example: TS-SR-45C, amber color LEDs and 2 connection cables

TS - SR - 45C - A A - C 2

Product Series

LED's Color for Side 1
LED's Color for Side 2

See "Cable Layout"

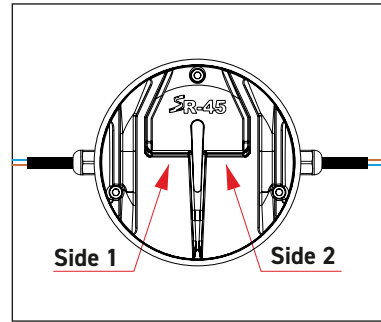

- Colors**
- W = White
 - WW = Warm White
 - R = Red
 - A = Amber
 - G = Green
 - B = Blue

Cable Layout

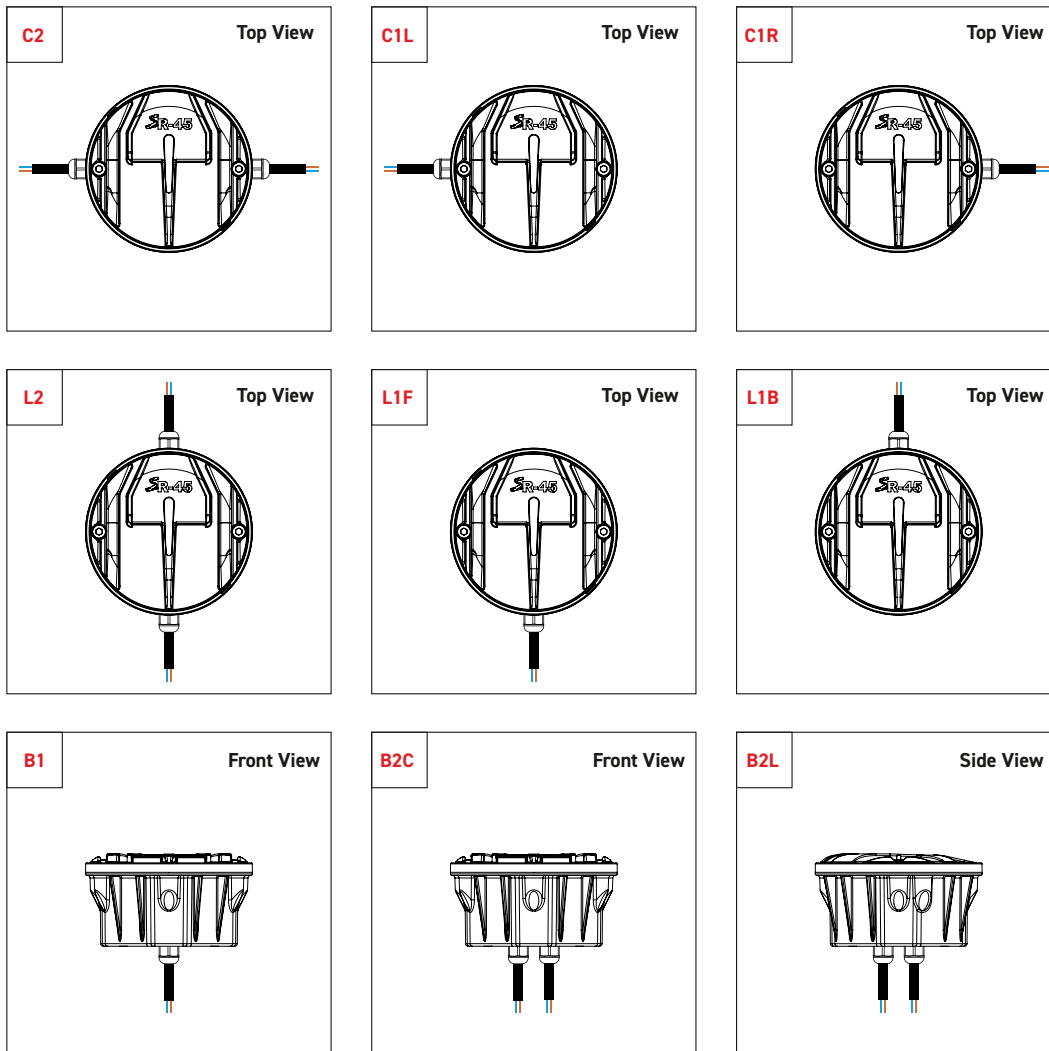

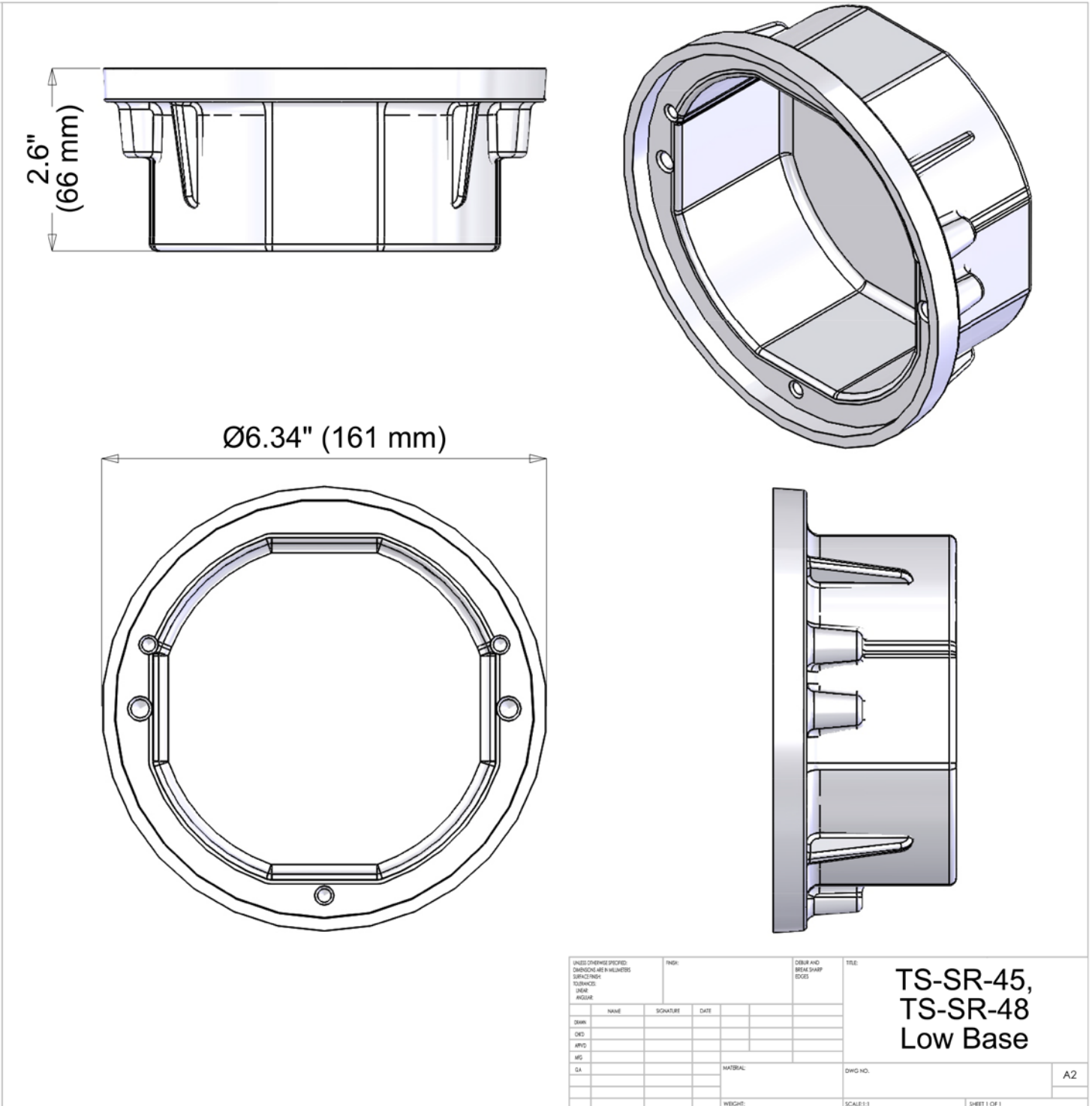

Note: TS-SR-45C road studs are fully compatible with existing aluminum bases from previous generations, allowing seamless upgrades without the need to replace the installed bases.

+1.888.446.9255 USA
+1.916.394.9884 Worldwide

xwalk.com
sales@xwalk.com

Traffic Safety Corp., 2708 47th Ave.
Sacramento, CA, 95822, USA